

Osaki

OS-4D Achilles

INSTRUCTION MANUAL

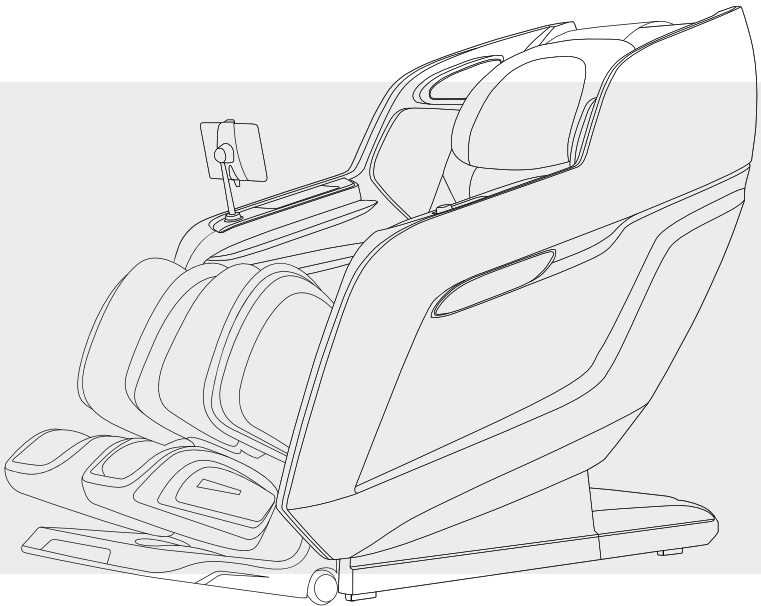

Please read all instructions carefully before using.

Thank you for purchasing this product. Please read this USER MANUAL carefully before using to ensure proper operation; please pay special attention to important safety warnings when reading and keep this USER MANUAL properly for future reference.

Contents

01 SAFETY PRECAUTIONS

02 NAME AND FUNCTION OF EACH COMPONENT

External Structure.....	3
Internal Structure.....	3
Power Box.....	4
Quick Buttons.....	5
Instructions of Armrest Quick Buttons.....	6
Tablet Controller.....	7
Tablet Controller Instructions.....	7
Off-line Voice Control.....	11

03 PRELIMINARY CHECKS

Position & Placement for Installation.....	12
Floor Protection.....	12
Surrounding Environment.....	12
Grounding.....	12
Installation Method.....	13
Moving the Massage Chair.....	15
Connecting to Power.....	15
Commissioning.....	16
Before Sitting in the Chair.....	16
After Use.....	16
Care Instructions.....	17





04 PRODUCT CARE AND STORAGE

05 TROUBLESHOOTING

06 TECHNICAL SPECIFICATIONS

01 SAFETY PRECAUTIONS

- ▶ Please read all instructions before using.
- ▶ Precautions and warnings listed below will help to ensure proper operation of this appliance.
- ▶ the classes of accidents caused by incorrect use are classified into WARNING and CAUTION. Read all WARNINGS and CAUTIONS below and follow all instructions within this manual.

 WARNING	Improper operation may cause injury to users.		
 CAUTION	Improper operation may cause injury to users or damage to product.		
	Prohibited		NO Disassemble

Not suitable for below persons

We recommend that those with any of the following conditions should consult your physician before using.

 WARNING	<ul style="list-style-type: none"> ◆ Those with pacemaker or electronic devices implanted in the body. ◆ Those undergoing treatment, especially those who are not feeling well. ◆ Those with osteoporosis, distorted joints, dysfunction or recent fracture. ◆ Those with serious or injured skin conditions; those who are recovering from illness or those who are frail. ◆ Those who are pregnant or menstruating. ◆ Those with bad fever. ◆ Those with malignant tumors, malignant abscesses, hypertension or heart disease. (need to be supervised) ◆ This product is equipped with heat function, persons with reduced sensory of heat should pay attention to it. (need to be supervised) ◆ Close supervision is necessary when this product is used by, on, or near children, invalids, or disabled persons. (need to be supervised)
---	---

Controller Precautions

 CAUTION	<ul style="list-style-type: none"> ◆ Do not operate the controller with wet hands or pull the controller wire by force. ◆ Do not spill water or other liquid into the controller to avoid fault. ◆ Do not lay heavy items on the controller.
---	---

Cautions Regarding the Power Connectors and Power Cord





 CAUTION	<ul style="list-style-type: none"> ◆ Use matching socket outlet only, improperly grounded appliance may cause risk of electrical shock. ◆ Connect the appliance only within the specified voltage to avoid damage to the product or causing fire. ◆ Never plug in or pull out power cord with wet hand to avoid shock or injury. ◆ Do not drag the cord, reach to the front plastic end to unplug it. ◆ Do not put heavy objects on the power cord. ◆ Do not damage, over bend, pull hard or twist the power cord. ◆ Do not operate the massage chair if the power cord is wet or broken. ◆ If the supply cord is damaged, it must be replaced by the manufacturer or its service agent or a similarly qualified person in order to avoid a hazard.
---	---

01 SAFETY PRECAUTIONS

Best Circumstances

 CAUTION	<ul style="list-style-type: none"> ◆ Do not use this appliance where temperature is over 40°C. ◆ Do not use this appliance in moist or dusty environment. ◆ Unplug from outlet during thunder or lightning storms. ◆ Do not use outdoors. ◆ Do not store near heat ,open flame or in direct sunlight . ◆ Please place the product on the flat level floor.
---	--

Best Practices for Safe Use

 CAUTION	<ul style="list-style-type: none"> ◆ Only for users weigh below 120kg. ◆ Do not use other therapeutic device which is not recommended by us together with this product. ◆ Use this product only for its intended use as described in this manual,do not use other therapeutic device together with this product. ◆ Appliance should only be used by one person,do not use by two or more persons at the same time. ◆ Do not use the product right after meal, it may cause discomfort. ◆ Please make sure no ornaments wearing before use to avoid any injuries. ◆ Check the upholstery under the cushions and other spots, if any damages are present, do not use it and refer to a qualified service professional for servicing. ◆ If you feel any abnormal discomfort during the operation of this product, stop use immediately. ◆ It is not recommended to use the unit for more than 30 minutes and not more than 5 minutes for particular part of the body to avoid muscle or nerve pain. ◆ Contact your doctor and stop using the product immediately if you experience severe it chiness or rash while in use. ◆ Make sure there is no obstacles behind the chair and there is enough clearance before adjusting the backrest or footrest angle. ◆ Make sure no other excessive load pressed on the backrest or footrest, keep children, pets or any other barrier away from the unit reclining backrest/extending footrest to prevent any accidental injury. ◆ Please be seated properly while using the appliance to avoid injury to the user or damage to the appliance. ◆ Don't drag or push the chair or roll on its casters on wood floor or carpet to avoid damage.
 PROHIBITED	<ul style="list-style-type: none"> ◆ Never operate this product if it has damaged / exposed parts or power leakage. ◆ Do not stand on or stack heavy objects on the footrest. ◆ Children should be supervised to ensure that they do not play with the massage chair. ◆ Do not fall into sleep while the product is operating. ◆ Avoid using the product under the influence of alcohol. ◆ Do not put fingers or foreign objects in the openings of the appliance to avoid injury to the user or damage to the appliance. ◆ If there is any smoke or unusual smell while using,stop using immediately, unplug the power cord.
 NO DISASSEMBLE	<ul style="list-style-type: none"> ◆ Do not disassemble this product yourself to avoid product failure. ◆ Do not attempt to repair or dismantle the appliance without permission.please contact authorized dealer or service agent for servicing.
 UNPLUG POWER CORD	<ul style="list-style-type: none"> ◆ Never plug in or pull out power cord with wet hand to avoid shock or injury. ◆ Pull out the power cord from the power strips before maintenance or after use. ◆ Unplug from outlet when the power supply is cut.

02 NAME AND FUNCTION OF EACH COMPONENT

External Structure

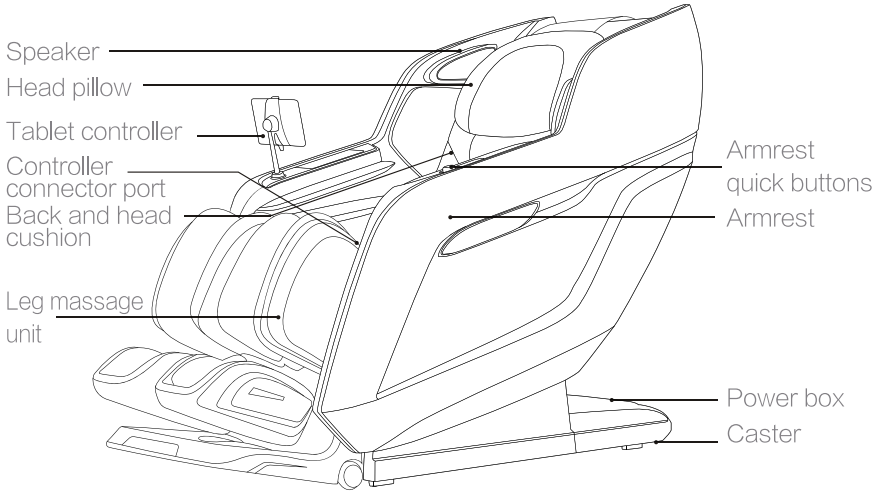

Internal Structure

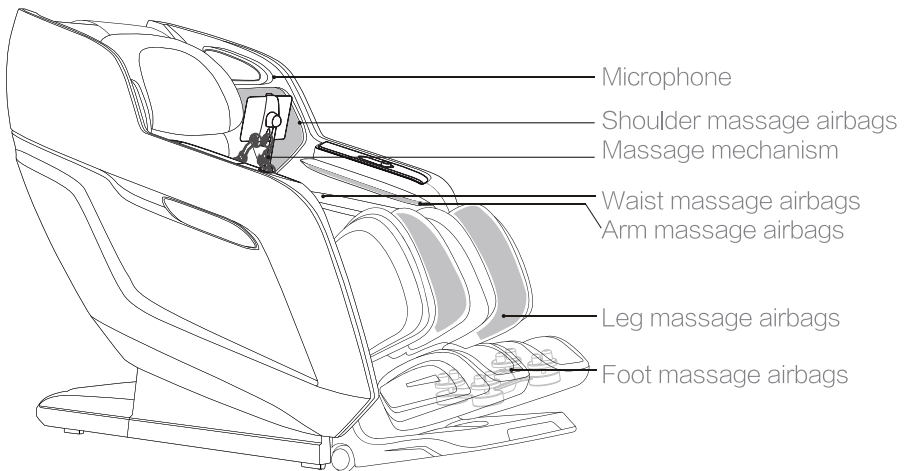

02 NAME AND FUNCTION OF EACH COMPONENT

Power Box

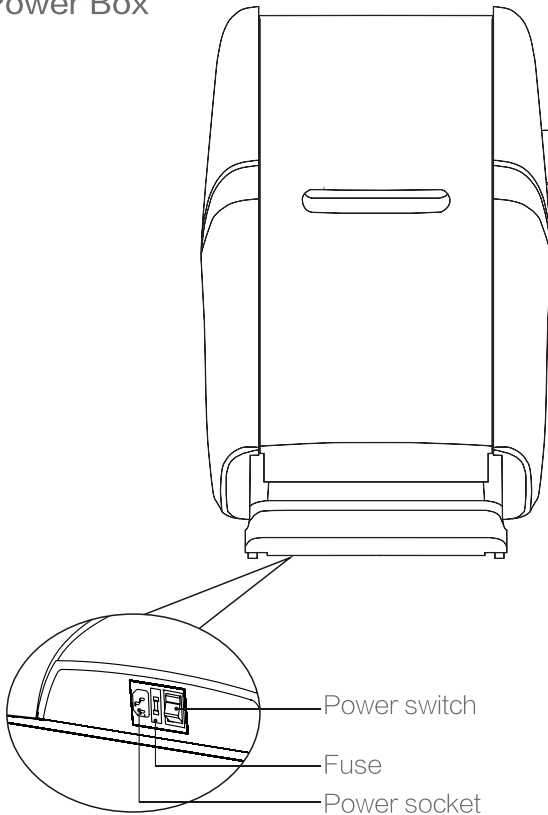

CAUTION

- ▶ Children should be supervised to ensure that they do not play with the chair or touch the power box.
- ▶ Always unplug the massage chair from the electrical outlet immediately after use.
- ▶ Unplug from outlet during thunder or lightning storms.
- ▶ Turn off the power switch and unplug the massage chair from the electrical outlet while not in use to avoid children power on the massage chair accidentally.
- ▶ When not in use for a long period of time, we recommend that the chair be covered, the power cord be coiled and that the unit be placed in an environment free of dust and moisture.

02 NAME AND FUNCTION OF EACH COMPONENT

Armrest quick buttons

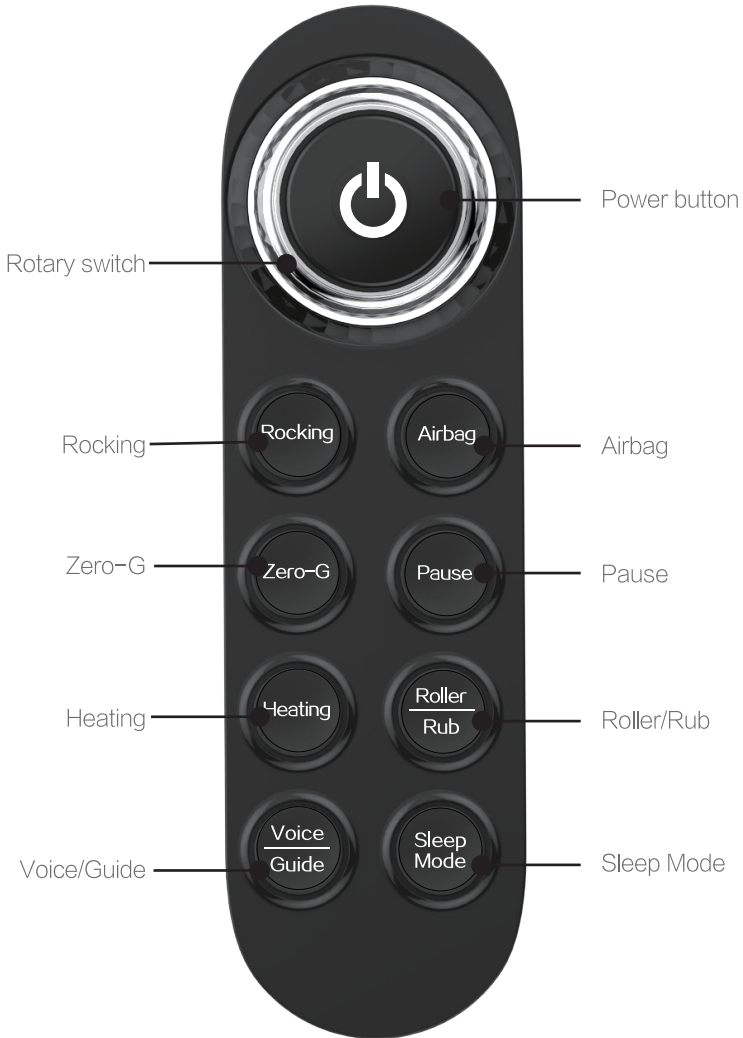

02 NAME AND FUNCTION OF EACH COMPONENT

Instructions of Armrest Quick Buttons



Power Button

Long press power button to turn on/off.

Short press to toggle between sweet dreams, power nap, bedtime unwind, Chinese massage, Thai massage, healthy breath.



Rotary switch

Rotate clockwise/counterclockwise to increase/decrease 4D massage intensity.



Rocking

Short press to turn on/off rocking function.



Airbag

Short press to toggle airbag kneading, airbag pulsing, airbag alternating.



Zero-G

Short press to toggle between Zero Gravity position 1, position 2, and off.



Pause

Short press to pause/continue massage.



Heating

Short press to toggle between Heating level 1, level 2, level 3, and off.



Roller/Rub

Short press to toggle between forward, reverse, alternating, foot roller off.

Short press to toggle between Calf Rubbing level 1, level 2, level 3, and off.



Voice/Guide

Short press to toggle between voice control on/voice control off.

Hold to toggle between voice guide on/voice guide off.



Sleep Mode

Press to end massage without restoring, the device will shut down after 2 minutes or restore after massage ends, and shut down after 2 minutes.

Note: The default setting for the next startup will be the previous operation.

02 NAME AND FUNCTION OF EACH COMPONENT

Tablet Controller

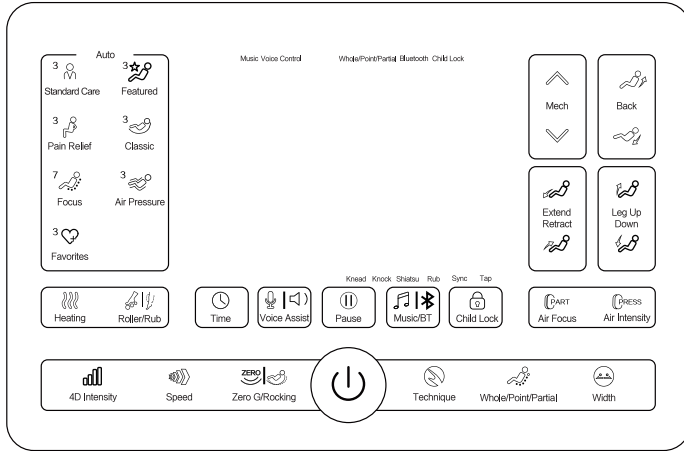

Tablet Controller Instructions

Auto Massage Programs

Featured – Sweet Dreams

Its exclusive massage techniques can help alleviate various discomfort such as sedentary neck, shoulder, waist and back pain. Coupled with soft ambient music, it can help relax the mind and sleep better.

Featured – Power Nap

It is suitable for midday break to help soothe tension, improve digestion, enhance performance, and boost creativity.

Featured – Bedtime Unwind

This massage program helps to promote blood circulation and relax body and mind, effectively alleviating various discomfort caused by lack of sleep, such as body discomfort, lethargy, slow response, headache and poor memory. It can help smooth the mind and melt away tension.

Standard Care – Gentle

Designed to pamper and empower, women's massage provides a personalized spa-like experience in the comfort of your own home. It's like having a private masseuse at your fingertips.

Standard Care – Medium

Tailored program for men, men's massage offers customized massage techniques to help relax the body and alleviate fatigue.

Standard Care – Strong

Specifically designed for elderly individuals, this program primarily focuses on gentle and soothing techniques, stimulating pressure points. This stretches the muscles throughout the body, help maintaining your own wellbeing.

02 NAME AND FUNCTION OF EACH COMPONENT

Pain Relief – Neck & Shoulder

Using a unique 3D massage design, the rollers target the shoulder and neck area, alleviating pain with pressing and lifting motions. This method aids in headache relief caused by shoulder and neck tension.

Pain Relief – Waist & Hip

Designed for people with sedentary lifestyles, it helps to boost blood circulation, relieve back and waist pain, improve sleep and release body fatigue.

Pain Relief – Back & Spine

Following the curve of the human body, this massage program uses combination of rolling, pushing and pressing massage techniques to help increase blood circulation.

Classic – Chinese Massage

Chinese massage uses strong penetrating massage techniques on acupoint and reflex areas to relieve pain, release both physical and mental tension, restore balance and kickstart the body's healing process.

Classic – Thai Massage

Thai massage primarily focuses on Thai-style stretching, emphasizing full-body stretching and relaxation, as well as local stretching of the neck, back, and waist. Thai health massage can help relieve fatigue, restore physical fitness, and enhance the vitality of joints.

Classic – Healthy Breath

This massage program helps ease and calm the mind by implementing breathing exercises with the massage chair voice commands and massage motions.

Focus Massage

Head Massage: Head Massage helps relieve stress and exhaustion.

Neck Massage: Neck Massage helps alleviate neck pains, tension and stiffness.

Shoulder Massage: Shoulder Massage is designed for shoulder relief, and helps ease muscle tension and pain of shoulders.

Back Massage: Back Massage helps relieve muscle tension and pain of the upper back.

Waist Massage: Waist Massage can help improve lumbar stiffness, alleviate lumbar muscle tension and pain.

Hip Massage: Hip Massage can help lymphatic drainage, shape and tone hip muscles.

Leg Massage: Targeting the legs, the massage involves movements to activate leg joints and leg rubbing for relaxation. Foot airbags hug the feet, while leg airbags move upward to compress the calves.

Air Pressure Massages

Airbag Kneading: Uses compressed air which simulates the kneading action of a human hand to relieve tension and soreness.

Airbag Pulsing: Airbags inflate and deflate in a rhythmic pattern to help improve blood circulation.

Airbag Alternating: Apply deep pressure to specific areas of the body to improve overall relaxation.

Favorites

Long press this button to add the currently running automatic program as a favorite or remove the currently running automatic program from favorites. Press and hold this button to add current running Auto massage program to Favorites or remove current running Auto massage program from Favorites; Short press this button to toggle among Favorite 1, Favorite 2 and Favorite 3.

Favorite programs are full: The favorite program list is full and cannot be added. Please remove one before adding. For programs not in favorites, please run the program first and long-press the favorite button to add it.

02 NAME AND FUNCTION OF EACH COMPONENT

Other Buttons



Power Button: Power on/off the massage functions.

Press the power button to turn on the product when the power is off, the controller screen lights up. Press the power button to turn off the power and restore when the product is working. Press any button on the controller to stop the restoration and cut the power immediately.



Air Pressure Intensity

Press this button to adjust air pressure intensity levels, indicator on the screen lights up accordingly. In Manual/Auto mode, you may toggle among level 1, 2, 3, 4, 5 air pressure intensity, and air pressure off. The indicator lights up/down accordingly.



Air Pressure Focus

Press this button to choose air pressure massage, you may toggle between upper body air pressure, lower body air pressure and whole body air pressure, the indicator lights up/down accordingly. When air pressure massage is off, press Air Pressure Intensity button can start air pressure massage.



Whole/Point/Partial

Under manual massage mode, press this button to toggle between Whole/Partial/Point massage mode. Whole Body Massage: Massage mechanism travels up and down along the full back, hips and thighs, the indicator blinks accordingly. Point Massage: Focus massage on current point, you may move the mechanism up/down by pressing the mechanism up/down adjustment button. Partial Massage: Focus the massage on current zone, you may move the mechanism up/down by pressing the mechanism up/down adjustment button, the indicator blinks accordingly.



Techniques

Under manual mode, press this button to toggle between: kneading, knocking, shiatsu, rubbing, sync and tapping massage techniques.



Massage Width

Under manual mode, press this button to toggle between Narrow, Medium and Wide massage width settings, the indicator lights up accordingly. Width is not adjustable in kneading, rubbing or sync massage mode.



Massage Speeds

Under manual mode, press this button to toggle between level 1, 2, 3, 4, 5 speed settings, the indicator lights up accordingly.



4D Intensity

Under manual mode, press this button to toggle between level 0, 1, 2, 3, 4, 5 speed settings, the indicator lights up accordingly. Under Auto mode, press this button to toggle among level 1, 2, 3, 4, 5 speed settings, the indicator lights up accordingly.



Time Settings

Press this button to toggle among 10 minutes, 20 minutes, 30 minutes time settings.

02 NAME AND FUNCTION OF EACH COMPONENT



Pause

Press this button to pause all the current massage functions; press again to continue.



Heating

Press this button to choose heating settings, the indicator lights up/down accordingly. Heating level 1, Heating level 2, Heating level 3, Heating off.



Roller/Rub

Short press: Forward/Reverse/Alternating/Foot Roller Off.
Hold: Calf rubbing level 1, Calf rubbing level 2, Calf rubbing level 3, Calf rubbing off.



Zero Gravity/Rocking

Short press to toggle between Zero Gravity position 1, Zero Gravity position 2, Zero Gravity off.
Hold to turn on/off rocking function.



Mechanism Up/Down

Press and hold Mechanism Up/Down button to move the mechanism to desired positions, the indicator lights up accordingly.
Press and hold Mechanism Up/Down button to adjust the rollers to the desired position while in the Shoulder scan procedure.



Backrest Up/Down

Press and hold to lift/recline the backrest; release the button to stop.



Child Lock

Press the Mechanism up and Mechanism down buttons at the same time to activate the child lock, and press again to deactivate the child lock.



Music/Bluetooth

Under the automatic program, press this button to adjust the background music volume.
Short press: Volume 1, Volume 2, Volume 3, Music off. Hold: Bluetooth Music On/Off.



Voice Control/Guide

Short press to toggle between Voice Control On/Voice Control Off.
Hold this button to toggle between Voice Guide On/Voice Guide Off.



Extend/Retract

Press and hold to extend/retract the legrest; release the button to stop.



Legrest Up/Down

Press and hold to lift/recline the legrest; release the button to stop.

02 NAME AND FUNCTION OF EACH COMPONENT

Off-line Voice Control

Tips: Please turn off ambient music or Bluetooth music to use off-line voice control.

Voice Command
Switch to Voice Mode
Sweet Dreams
Power Nap
Bedtime Unwind
Gentle
Medium
Strong
Neck & Shoulder
Back & Spine
Waist & Hip
Chinese Massage
Thai Massage
Healthy Breath
Change a program
Turn On
Power Off
Pause massage
Continue massage

03 PRELIMINARY CHECKS

Position & Placement for Installation

Clearance space for the massage chair:

- ▶ Please allocate a minimum 7-centimeter distance clearance for the back of the product;
- ▶ Please allocate a minimum 60-centimeter distance clearance for the footrest of the product.

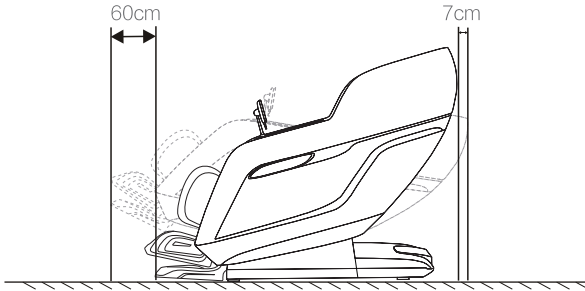

Floor Protection

- ▶ We recommend to place a piece of carpet or soft mat underneath it to avoid damaging the floor.

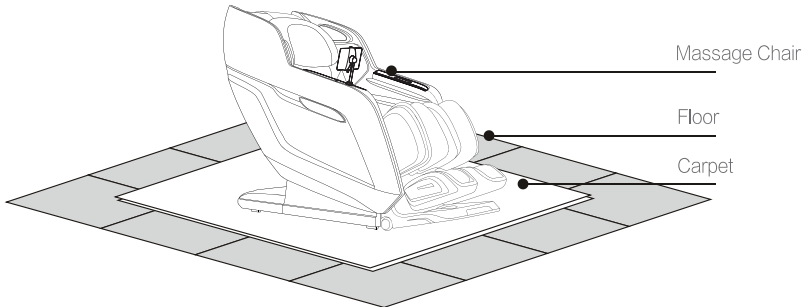

Surrounding Environment

- ▶ Do not use the massage chair in high moisture environment such as near swimming pool or bathroom to prevent electric shock accident.
- ▶ Please keep the massage chair away from heated surfaces to prevent fire hazard or damage to the product.



Grounding

- ▶ This product must be grounded, the plug must be plugged into an appropriate 3-wire grounded outlet that is properly installed and grounded in accordance with all local codes and ordinances to reduce risk of electrical shock.

03 PRELIMINARY CHECKS

Installation Method

Step 1: Take all massage chair units out of the cartons.

- ▶ Unpack the cartons and take all sewing and other accessories out of the cartons.
- ▶ Before beginning installation, please verify that all components are included (check with the packing list carefully).

Step 2: Install the Controller Unit

- ▶ Connect the controller cable to the massage chair's port (line up the pins with the port before connection), then tighten the screw cap clockwise to secure the connector in place.

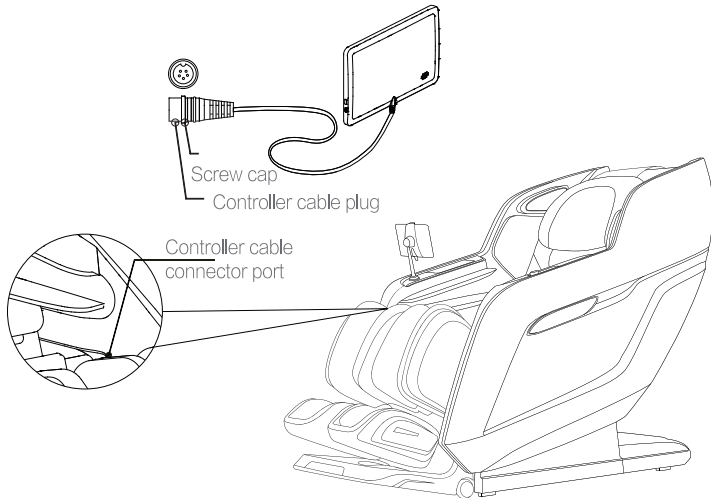

Step 3: Install the Controller

- ▶ Insert the lower end of tablet holder into the socket, turn the locknut clockwise to secure the holder into place (make sure the cradle face to the chair side).

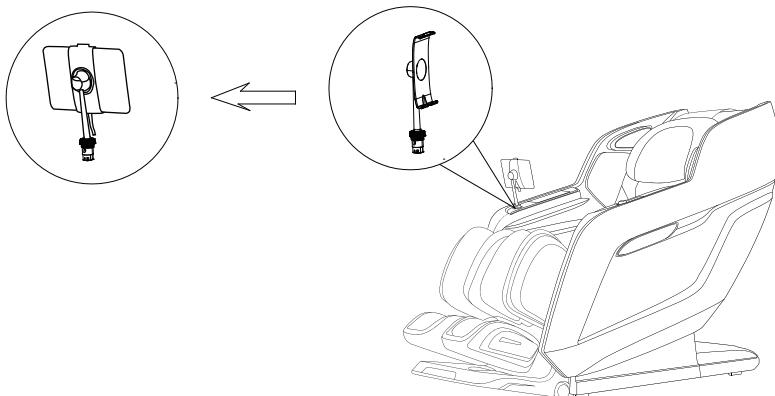

03 PRELIMINARY CHECKS

Step 4: Other Accessories

- ▶ Connect the power cable to the product power socket located at the power box.
Connect power to chair, switch ON the power button, use the controller to raise the backrest to fully upright position.

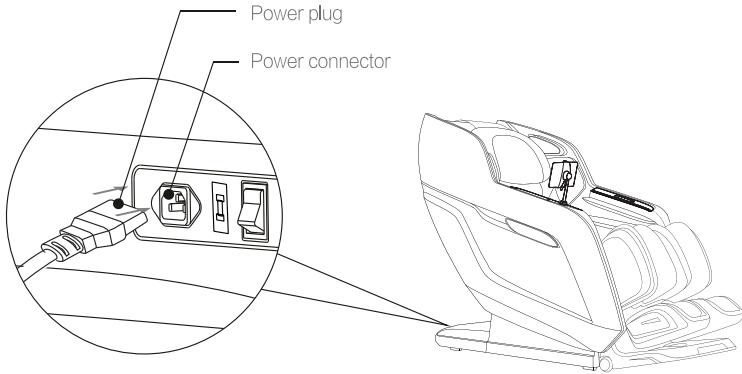

- ▶ Connect the power cable to the product power connector port located at the power box of the product. (Check the illustration below)

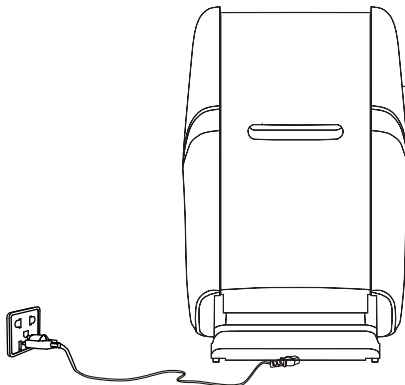

03 PRELIMINARY CHECKS

Moving the Massage Chair

- ▶ Roll the chair on its casters to the desired location.
- ▶ Incline the backrest to upright position.
- ▶ Turn off the power switch and unplug the appliance from the electrical outlet.
- ▶ Using two people, push down on the backrest and lift up on the front sides, roll the chair on its casters to the desired location (check the sketch for reference).

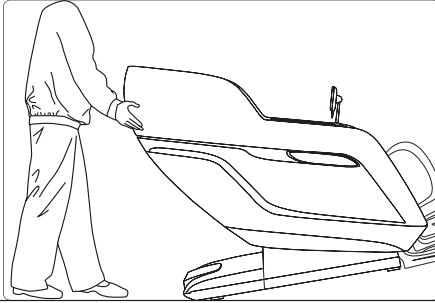

CAUTION

- ▶ Do not move the chair when there is user inside.
- ▶ To carry this product, do not lift by the footrest or armrest, hold the chassis and steady the backrest (have 4 or more people to carry the product).

Connecting to Power

- ▶ Connect this appliance to a 3-wire properly grounded outlet.
- ▶ Turn on the main power switch located at the power box of the product.

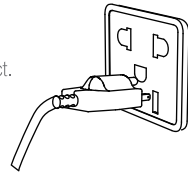

CAUTION

- ▶ Please verify that there is no damage to the supply cord before switching on the massage chair.
- ▶ Please verify that the main power switch is turned off before connecting to power.

03 PRELIMINARY CHECKS

Commissioning

- ▶ Use the controller to recline the backrest to its lowest position, raise and extend the footrest to its top position, make sure there is enough clearance before commissioning.
- ▶ Return the backrest and footrest back to its default position after commissioning and turn off the power switch. (To choose the massage program, please check the Controller Instructions for reference)

Before Sitting in the Chair

- ▶ Ensure the footrest is well assembled before sitting on the massage chair.
- ▶ Ensure the massage chair is returned to its original position before sitting on it.
If there is any part not in default position, please turn on the massage chair to allow it to restore.



CAUTION

- ▶ Do not take seat while the legrest is lifted.
- ▶ Do not put excessive load on the legrest to avoid damage.



WARNING

- ▶ Do not play on the massage chair or operate it improperly.
- ▶ Ensure there is no obstruction when raising or reclining the backrest and footrest.
- ▶ Do not put foot, fingers or any other objects in the openings of the chair when it is in the reclining, raising or restoring motion.
- ▶ Ensure that massage chair is restored back to its original position before getting off the massage chair.

After Use

- ▶ Always unplug the massage chair from the electrical outlet immediately after use.
- ▶ Turn off the power switch and unplug the massage chair from the electrical outlet while not in use to avoid children power on the massage chair accidentally.
- ▶ When not in use for a long period of time, we recommend that the chair be covered, the power cord be coiled and that the unit be placed in an environment free of dust and moisture.

04 PRODUCT CARE AND STORAGE

Care Instructions

- ▶ To treat stains on the back panel, armrest, footrest, plastic parts or air hose, spot clean with mild detergent foam, then wipe it with a dry cleaning cloth.
- ▶ To treat stains on the controller, power box, spot clean with a dry cleaning cloth.
- ▶ To treat stains on the back cushion or pillows, use a water-based upholstery cleaner only, wipe it with moist cloth, then air dry.
- ▶ To clean the foot / leg unit covers, remove it from the chair, hand wash with a mild detergent, then line dry.



WARNING

- ▶ Pull out the power cord from the power strips before care and maintenance.
To avoid electrical shock or injury, do not touch the power cord with wet hands.
Make sure no detergent enter into the power box while cleaning.
- ▶ Do not use benzene, thinner or other solvents on your product, it may cause fading or damage to the product.
- ▶ Do not iron the upholstery.

Storage Methods

- ▶ Cover the product with a dust-free cloth to prevent the collection of dust if not in use of a long period of time.



CAUTION

- ▶ Do not leave this product exposed to direct sunlight for long periods of time. This may cause fading or damage.

Warm Tips

During daily use, please check for the following symptoms:

- ▶ Burnt smell.
- ▶ Power flickers on and off when touching the charging cable.
- ▶ The power cord is hot.
- ▶ Other abnormal symptoms.



CAUTION

- ▶ Please stop using the product to avoid breakdowns or accidents if any above symptom exists.
- ▶ Switch off the power button and disconnect the plug, contact us or the dealer for repair.
- ▶ All other servicing except above care and maintenance should be serviced by an authorized dealer or service center.



WARNING

- ▶ Pull out the power cord from the power strips before care and maintenance.
- ▶ To avoid electrical shock or injury, do not touch the power cord with wet hands.
- ▶ Do not try to dismantle or repair the product yourself, please send your massage chair to the authorized service center.

05 TROUBLESHOOTING

No.	Symptoms	Possible Causes	Possible Solutions
1	There is operational noise during use	This sound is normal and comes from the air compressor motor or other mechanical parts rubbing against the cloth cover	No need to take any measures
2	The chair does not turn on	The power cord is not secured into the socket	Secure it into a well-functioned electrical outlet
		Power Switch is off	Turn on the switch
		The fuse is blown	Replace only with a fuse of same type and rating
3	The speaker is not playing music	The volume is turned to the lowest	Adjust the speaker volume from the mobile devices
		Bluetooth didn't connect with music device	Reconnect Bluetooth
4	The backrest or footrest does not move	Excessive load has been pressed on the backrest or legrest	Reduce the load and try again
5	The airbag is not working	The air hose is blocked	Straighten the air hose and clear out the blockage

If problem remains, please contact us or authorized service center for maintenance.

Important: Do not attempt to repair this product yourself, our company shall not be liable for the injury or damage caused by any servicing without authorization.

06 SPECIFICATIONS

Product name : OS-4D Achilles Massage Chair
Model : OS-4D Achilles
Rated voltage : 110V~
Rated frequency : 50Hz-60Hz
Rated Currency : 0.9 A
Safety design : Class I

IMPORTANT SAFETY INSTRUCTIONS

Read all instructions before using (this appliance).

DANGER – To reduce the risk of electric shock:

1) Always unplug this appliance from the electrical outlet immediately after using and before cleaning.

WARNING – To reduce the risk of burns, fire, electric shock, or injury to persons:

1) An appliance should never be left unattended when plugged in. Unplug from outlet when not in use, and before putting on or taking off parts.

2) Do not operate under blanket or pillow. Excessive heating can occur and cause fire, electric shock, or injury to persons.

3) Close supervision is necessary when this appliance is used by, on, or near children, invalids, or disabled persons.

4) Use this appliance only for its intended use as described in this manual. Do not use attachments not recommended by the manufacturer.

5) Never operate this appliance if it has a damaged cord or plug, if it is not working properly, if it has been dropped or damaged, or dropped into water. Return the appliance to a service center for examination and repair.

6) Do not carry this appliance by supply cord or use cord as a handle.

7) Keep the cord away from heated surfaces.

8) Never operate the appliance with the air openings blocked. Keep the air openings free of lint, hair, and the like.

9) Never drop or insert any object into any opening.

10) Do not use outdoors.

11) Do not operate where aerosol (spray) products are being used or where oxygen is being administered.

12) To disconnect, turn all controls to the off position, then remove plug from outlet.

13) Do not use massager in close proximity to loose clothing or jewelry.

14) Keep long hair away from massager while in use.

15) Use heated surfaces carefully. May cause serious burns. Do not use over insensitive skin areas or in the presence of poor circulation. The unattended use of heat by children or incapacitated persons may be dangerous.

SAVE THESE INSTRUCTIONS

For use household only

