

AI Revive 4D  
**MASSAGE CHAIR**  
— Operation Instructions —

**SAVE THESE INSTRUCTIONS**

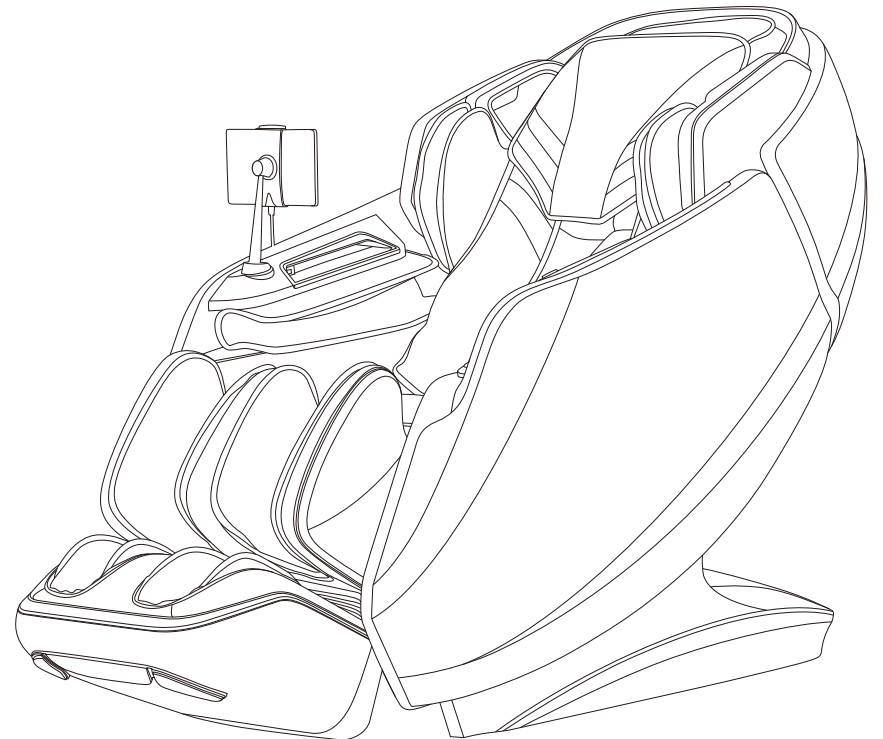

Thanks for purchasing this product. Please read this manual instruction carefully in order to know how to use this product correctly before operation. Please pay more attention to some important safety warning and keep this manual book properly for future use.

Note: Our company reserves the right to change and explain the design of the product. If there is some difference between the product function in market circulation and the description in the manual, it is a normal update of the product, and our company will not inform you otherwise. The specific product function and color shall prevail in kind.

## CONTENTS

### Before use

---

|                     |       |
|---------------------|-------|
| Safety precautions  | 02-05 |
| Installation parts  | 06-07 |
| Place massage chair | 08-09 |
| Before use          | 10-11 |
| Product structure   | 12-18 |

### Usage method

---

|                        |       |
|------------------------|-------|
| Operation Instructions | 19-53 |
| End massage            | 53    |

### Maintain

---

|                          |    |
|--------------------------|----|
| Cleaning and Maintenance | 54 |
|--------------------------|----|



### Important

---

|                        |    |
|------------------------|----|
| Troubleshooting        | 55 |
| Product Specifications | 56 |

## Safety Precautions (Must be observed)

- Please read all relevant instructions carefully before use.
- The notes marked here will help you to use the product safely and correctly.
- In order to clearly indicate the extent of harm and damage, precautions are divided into **"Warning"** and **"Caution"** that may be caused by incorrect use. Both of them are important for safety and must be followed.

|  |  |
|--|--|
|  <b>Warning</b> | Indicates that serious injury or death may result from improper use. |
|  <b>Caution</b> | Indicates that misuse may cause minor injury or property damage.     |

- Please pay attention to the symbol before each safety item.

|  |                      |
|--|----------------------|
|  <b>Forbidden</b> | Absolute prohibition |
|--|----------------------|

### The following populations should not use this product

|   |  |
|---|--|
| <br><b>Forbidden</b> | <ul style="list-style-type: none"> <li>■ The device is not intended for use by persons (including children) with physical disabilities, sensory or neurological impairments or who lack experience and common sense, unless they are supervised and instructed in the use of the device by those responsible for their safety. Children must be supervised to ensure they do not use tools for play.</li> <li>■ Patients with osteoporosis.</li> <li>■ Patients with severe heart disease and wearing implantable medical devices such as pacemakers and defibrillators that are susceptible to electromagnetic waves.</li> <li>■ People who have a fever (above 38 degrees ).</li> <li>■ Pregnant women or shortly after childbirth and during their menstruation period.</li> <li>■ People who follow medical advice and are prohibited from receiving massage due to thrombosis, aneurysm, severe varicose veins, or other circulatory diseases. Within two weeks after the appearance of blood clots, it is strictly prohibited to massage any form of body parts that have blood clots.</li> <li>■ Patients who are injured or have a skin disease.</li> <li>■ When unsupervised, any children are under the age of 14 and those unconscious are not allowed to use this product.</li> <li>■ People who require rest or feel unwell as instructed by a doctor.</li> <li>■ People with spinal abnormalities or scoliosis are prohibited from receiving this product due to medical advice due to other diseases.</li> <li>■ People whose bodies are wet are forbidden to use this product.</li> <li>■ This product has a hot surface. Persons insensitive to heat must pay attention when using this product.</li> </ul> |
|---|--|

## Safety Precautions (Must be observed)

### Important safety warnings

|  |   |
|--|---|
| <br><b>Warnings</b> | <ul style="list-style-type: none"> <li>■ Keep children away from the movable parts of this product.</li> <li>■ Use the well-grounded power supply unit suitable for this product.</li> <li>■ Pull out the plug after use or before cleaning to avoid any damage to physical injury or the product.</li> <li>■ Operate this product as instructed in this manual.</li> <li>■ Do not use any parts or accessories which are not recommended.</li> <li>■ Do not use this product outdoors.</li> <li>■ Do not use near open flames such as stoves, and do not smoke while using.</li> <li>■ Do not use heating equipment such as electric blankets on this product.</li> <li>■ Do not sit on the back of the chair, leg massagers, shoulders, armrests, or stand on the seat.</li> <li>■ Please read the Operation Instructions carefully before operation.</li> <li>■ Never use this product for any other purpose not listed in the manual .</li> <li>■ 20 minutes of usage each time is recommended.</li> <li>■ Do not use this product if the cover or leather is broken or damaged.</li> <li>■ Do not drop anything into this product.</li> <li>■ Never fall asleep while using this product.</li> <li>■ Do not use this product if you are drunk or feel unwell.</li> <li>■ Do not use this product within one hour after a meal.</li> <li>■ Do not use this product with excessive force to avoid any injury.</li> <li>■ Do not use for purposes other than massage.</li> <li>■ If the supply cord is damaged, to avoid danger, it must be replaced by a professional from the manufacturer, its maintenance department or similar department</li> </ul> |
|--|---|

### Operating environment

|   |   |
|---|---|
| <br><b>Caution</b> | <ul style="list-style-type: none"> <li>■ Do not use this product in a very moist environment such as the bathroom.</li> <li>■ Stop using this product immediately when the ambient temperature changes sharply.</li> <li>■ Do not use this product in any heavily-dusty or caustic environment.</li> <li>■ Do not use this product in a small space or a place without good ventilation.</li> </ul> |
|---|---|

## Safety Precautions (Must be observed)

### Storage conditions



Caution

- Storage room temperature: 5 °C to 40 °C.
- Relative humidity (RH) between 20% and 80%; free of corrosive gases, and a well-ventilated room.

### Product service and maintenance



Caution

- This product should be maintained by the service center designated by the manufacturer only. No user should disassemble or maintain it without permission.
- Do not forget to turn off the main power switch after usage.
- Do not use this product if the power socket becomes loose.
- If this product will be left unused for a long period of time, it is necessary to roll up the power cord of this product and store this product in a dry and dust-free environment.
- Do not store this product at a high temperature or near open flame. Avoid prolonged exposure to direct sunshine.
- Please clean this product with dry cloth. Never use thinner, benzene or alcohol.
- The mechanical components of this product are specially designed and manufactured, so no special maintenance is needed.
- Do not use a sharp object to stab at this product.
- Do not roll or pull this product on any uneven ground. Instead, it should be lifted before moving.
- Please use this product intermittently. Do not keep it working continuously for a long period of time.

### Solutions to ordinary malfunctions



Caution

- If the motor sounds during operation of this product, this is the normal operation sound.
- If the controller cannot work normally, check whether the plug and the power socket are connected reliably, and whether the power switch is turned on.
- If the rated working time is over, this product will automatically activate the power-off button; If this product keeps operating for a long period of time, the temperature protector will stop this product automatically. The product can be used again after half an hour.

## Safety Precautions (Must be observed)

### Safety precautions



Caution

- Check whether voltage is consistent with the specification of this product.
- Never insert or pull out the plug with a wet hand.
- Do not let water flow into this product to avoid electric shock or cause damage to this product.
- Do not pull the power cord when plugging or unplugging it. Rough handling is forbidden.
- Do not damage the wire or modify the circuit of this product.
- Do not clean live parts of this product with a wet cloth such as a power switch and plug.
- Be away from this product in case of power failure to avoid any injury if power is restored suddenly.
- Stop using this product at once while it works abnormal, and consult your local supplier.
- Stop using this product if you feel unwell, and consult your health care practitioner.

## Installation parts

### Armrest Installation Instructions

1. After power on, use the remote controller to lie down the backrest .
2. Insert the wire harness and air pipes on the side of the steel frame into the corresponding positions on the armrest (Figure 1).
3. Lift up the armrest with the air pipes and wires inserted, and hang all the hooks on both sides of the steel frame (Figure 2).

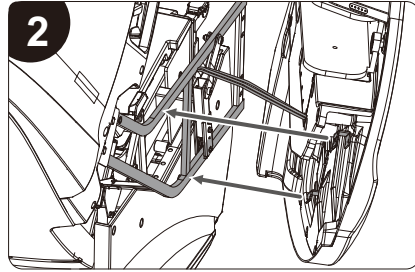
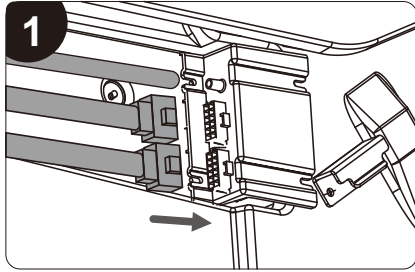

4. Press the roller at the rear end of the armrest into the corresponding slot (Figure 3), and lower the armrest downwards.

Then push the armrest backwards, and lock it with 2 M6\*16 screws (Figure 4).

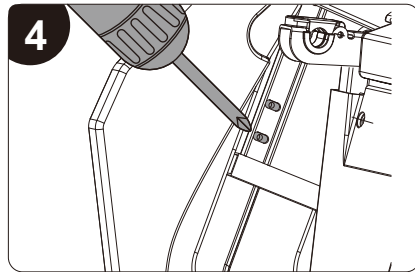
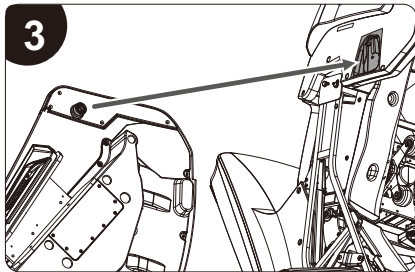

### Calf Installation Instructions

1. Insert the wires and air pipes of the footrest into the front sockets of the steel frame assembly respectively (Figure 1).
2. After the wire connection is completed, open the fixing covers of the footrest on both sides of the steel frame assembly (Figure 2).

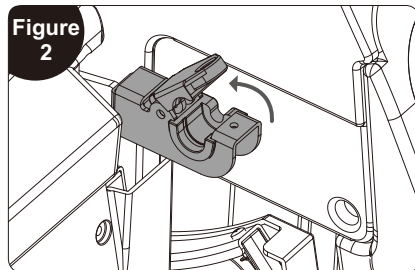
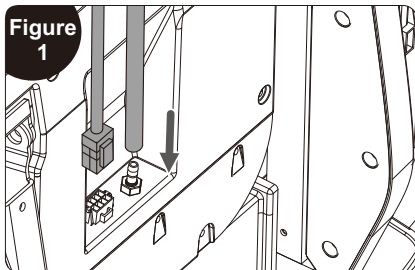

## Installation parts

3. Lift the footrest, put them into the slot, then flip the fixing cover down, fixing them with two M5\*16 screws (Picture 3).

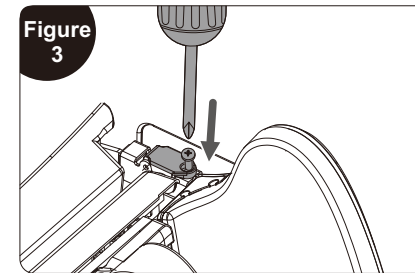

### Touchscreen Remote Controller Bracket Installation Instructions

1. Disassemble the M5X22 screw in the figure for later assembly (Figure 1).
2. Align the bracket with the front hole of the armrest (right) and fasten it with M5\*16 screws (Figure 2).

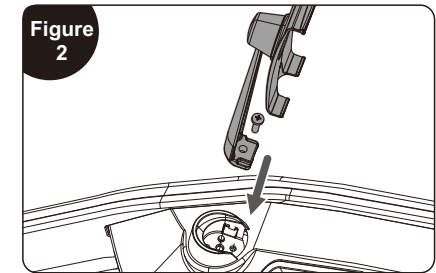
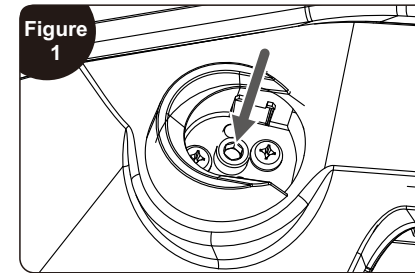

3. Align the bracket decoration with the bracket and press down along the bracket rod to the end. (figure 3).

4. After the entire bracket is installed, shake the bracket lightly to confirm whether it is firmly installed; the bracket installation is complete (Figure 4).

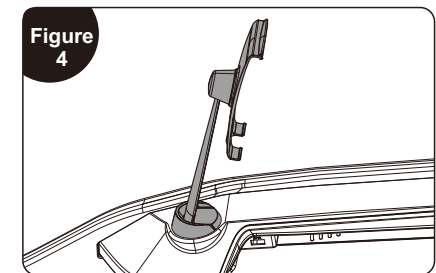
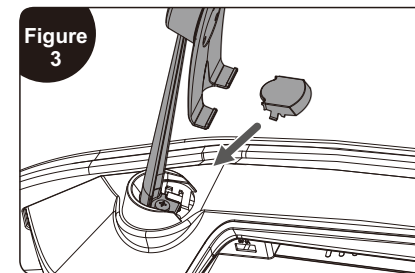

## Place massage chair

### Installation placement

**Make sure there is enough space for the massage chair can be tilted at least 8 cm.**



Do not expose the massage chair directly to high temperature environment due to sunlight (such as: in front of heating equipment), and place it to where can avoid high temperature and direct sunlight. It is recommended to lay a soft cushion for long-term use in a designated location. When laying the cushion, the size of the cushion should be enough to cover Keep the range where the machine touches the floor and the range where your feet touch the floor.

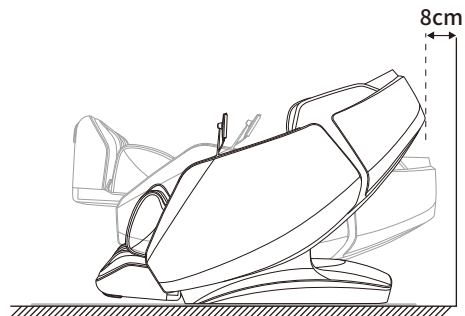

### Product lift instruction

**Require team work to lift and move the chair to avoid injury.**



1. Please lift the massage chair to move it on vulnerable ground such as wooden floor.
2. When moving on a similar wooden floor, it is recommended to lift it. Avoid damage to the casters. When the floor is lifted and moved to the designated position, be careful to keep your hands out of the way to avoid injury, and be careful of your feet being crushed. Do not let go of the unit until the unit is completely flat, the floor may be damaged, therefore, it is recommended to place mats, etc. on the floor.

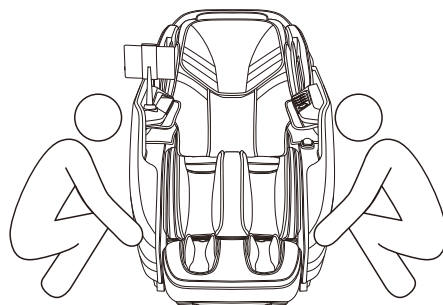

## Place massage chair

### Move method

**Use the rear casters to move the massage chair. Move the chair by tilting it down and backward about 45° as shown in the diagram.**



**NOTE: Excessive force to title will cause the chair to tip over completely and product damage.**

1. Before moving, please shut down the machine properly to reset the whole machine, and then cut off the power.
2. Please keep the chair vacant when moving. (People, pets or clutter will not be able to stay on the chair.)
3. When moving, do not cross a drop barrier higher than 2mm or a gap greater than 5mm.
4. When using casters to move this product, single continuous movement is not supported; if the distance exceeds 50 meters, please make this product move slowly and evenly.

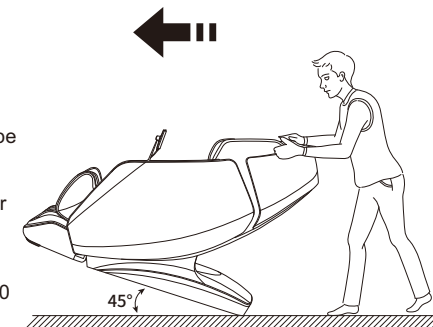

### How to disassemble and use headrest cushion and backrest cushion

Using a headrest cushion can reduce the intensity of kneading massage on the neck and shoulders, and you can decide whether to use a headrest cushion according to your needs (recommended to use a headrest cushion). The backrest cushion and the backrest are connected by a zipper (1), and the headrest cushion and the backrest cushion are connected by a zipper (2).

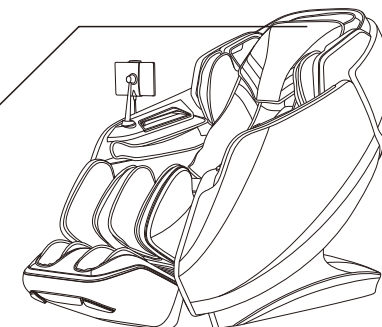
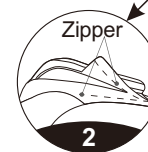

## Before use

### Check around

Make sure that there are no people, pets and other objects around the unit.

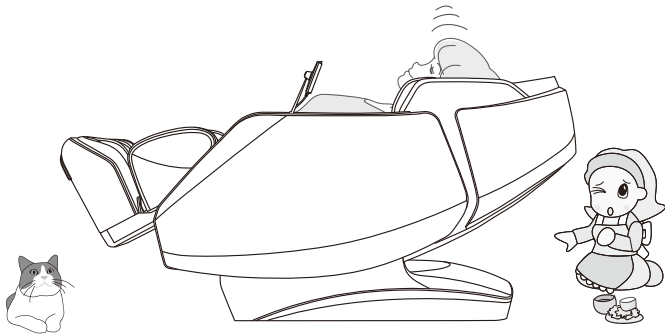

### Make sure there are no foreign objects in the gaps of the machine

Before massaging, make sure that no foreign objects are caught in the legs, feet, etc.

Under no circumstances allow hands, feet, and head to penetrate into the area between the lower leg mechanism and main body, or the area between the armrest and the capsule.

Under no circumstances should hands, feet, or head sink under the fabric or leather covering of the massage area.

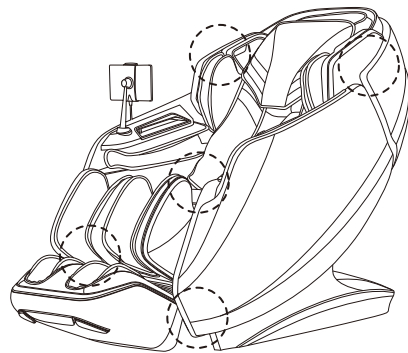

## Before use

### Turn on the power

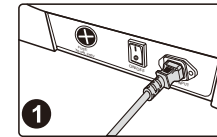

1

Plug in power cord

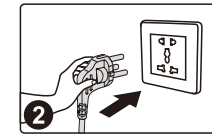

2

Schematic diagram of power on

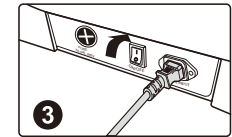

3

Turn on the power switch ("I" position)



- Please check the power cord and plug for damage before use.
- Please supply power to this product in accordance with the working power requirements of this product's calibration.
- It is strictly forbidden to use a power supply other than the nominal power supply of this product.
- It is strictly forbidden to connect various power conversion devices without authorization to supply power to this product.

## Product structure

### Description of Components

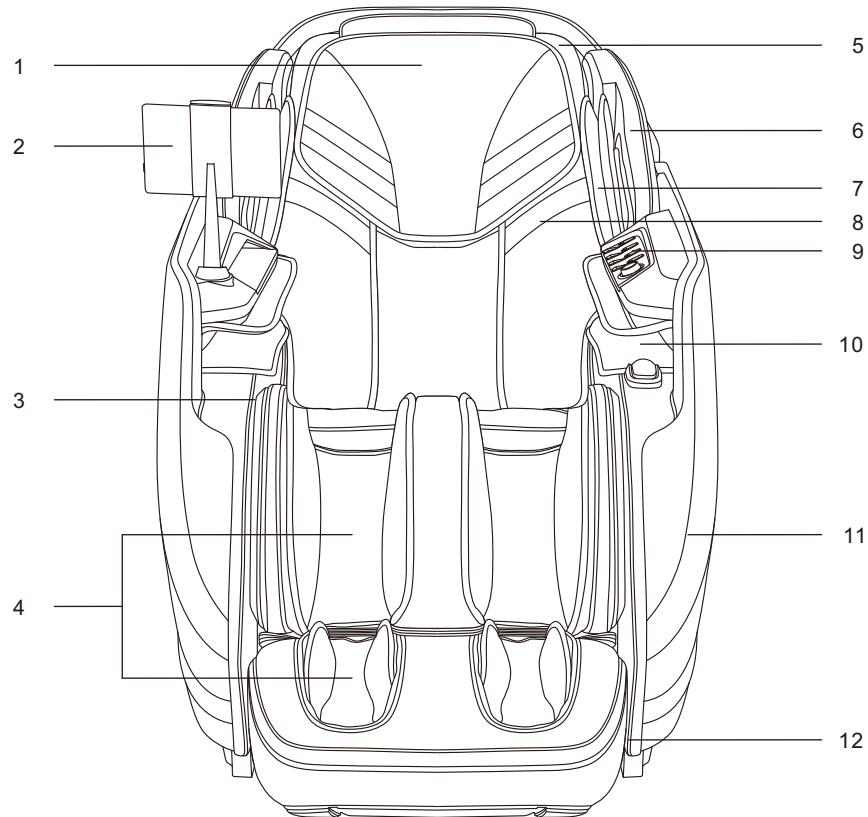

- 1.Head cushion
- 2.Remote controller
- 3.Arm air pressure
- 4.Leg massage unit
- 5.Ambient lighting
- 6.Space capsule

- 7.Shoulder air pressure
- 8.Shawl backrest cushion
- 9.Armrest Shortcut Keys
- 10.Health sensor
- 11.Armrest
- 12.Side panel

## Product structure

### Schematic view of functional distribution

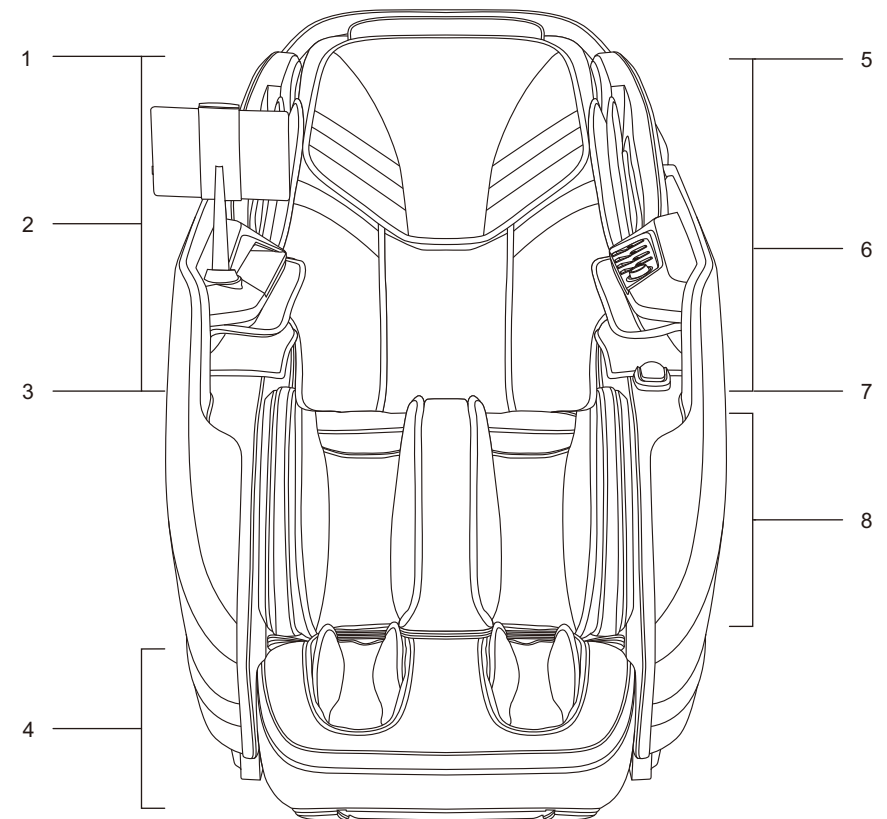

- 1.Shoulder
  - Airbag massage
- 2.Arm
  - Remote controller rest
  - Mobile phone placement rest
  - USB charging socket
  - Wireless charger
  - Built-in voice control microphone
- 3.Hand
  - Airbag massage
- 4.Sole
  - Roller massage
  - Airbag massage

- Electrically adjustable foot telescopic
- Automatic leg length detection
- 5.Both sides of the head
  - 3D digital player
  - Music player
- 6.Head & neck to seat part
  - Massage hand
- 7.Shoulder, back, waist, abdomen
  - Shawl heating function
- 8.Leg
  - Airbag massage
  - Kneading massage

## Product structure

### How to use the shawl

It features a unique shawl component, with innovative heating functions on the shoulder, back, waist and abdomen. Users can place the shawl at different massage positions according to massage requirements.

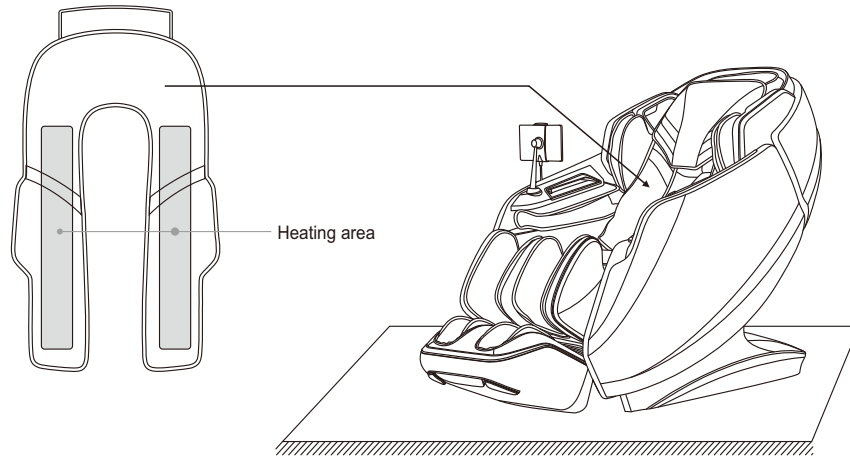

#### Schematic diagram of use on back and waist

When the shawl component is placed on the back and waist position, the shawl built-in heating, dredge the back meridians, promote blood circulation and warm the kidney, relieve low back pain, back cold stiffness, pain and other conditions.

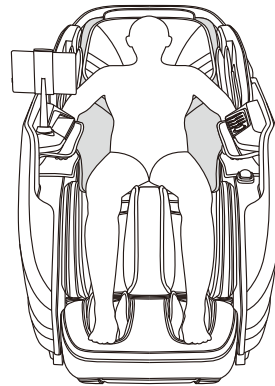

## Product structure

#### Schematic diagram of use on shoulder and abdomen

When the shawl component is placed at the shoulder position (front/rear), it will heat the acupoints such as Bingfeng, Tianzong, Yunmen and Qihu around the shoulder and clavicle through the shawl built-in heating; it can also be placed on the abdomen to heat the abdomen through the shawl built-in heating.

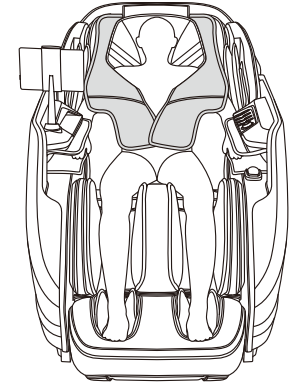

#### Use demonstration of the shawl on the back



**Caution**

1. Correct placement and use: When the shawl is used on the back (or the massage chair is not turned on), please place the shawl on both sides of the backrest and put the lower magnet and the backrest cushion lumbar position of the magnet corresponding suction well; if you do not need to use the shawl function, level the shawl and lift back behind the massage chair.
2. Wrong placement and use: When the shawl is used on the back (or the massage chair is not turned on), do not bring the shawl together in the middle massage hand, which may lead to functional failure, product failure and other serious faults. At the same time, do not fold, twist, cross the shawl, and place and use the shawl on your back.

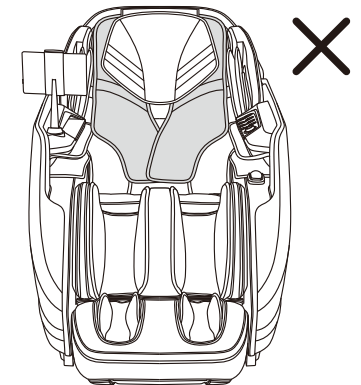
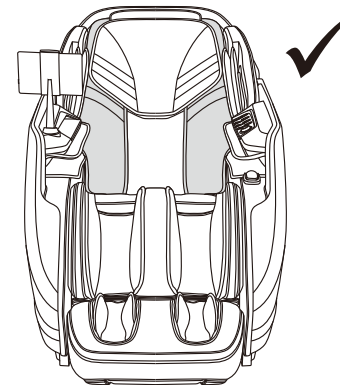

## Product structure

### Remote controller keys instruction

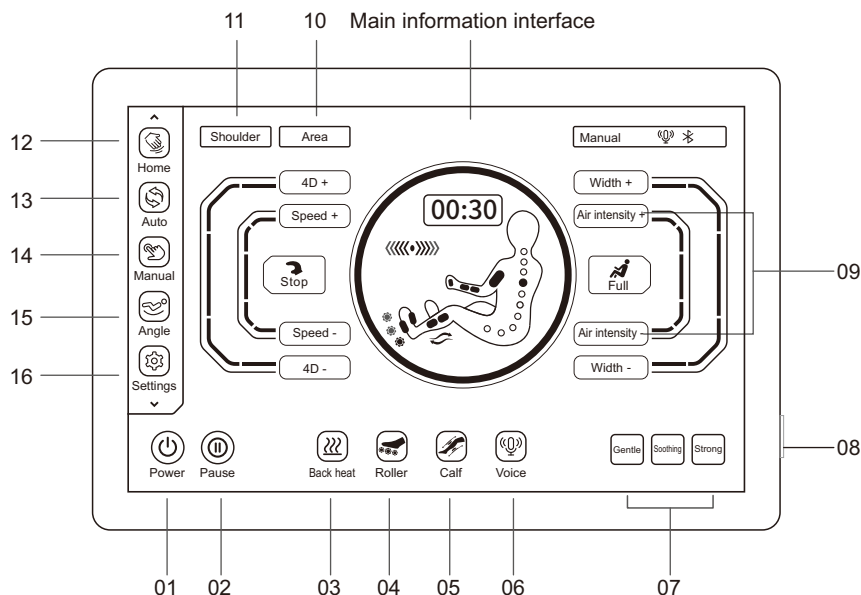

01. On/off touch key: Enable or disable the massage chair function.
02. Pause key: Pause the massage or exit from pause massage.
03. Back heating key: Enable or disable the back heating function.
04. Sole roller key: Enable or disable the sole roller function.
05. Calf kneading key: Enable or disable the calf kneading function.
06. Voice control key: Enable or disable the voice control function.
07. Intensity selection key: Select one from different automatic massage intensities.
08. Button on/off key: Turn on or off the massage chair.
09. Air intensity key: The function of regulating air intensity massage.
10. Massage area key: The function of selecting massage position.
11. Shoulder position adjustment key: Regulate shoulder position and confirm massage criterion.
12. Current status key: Enter to view current massage chair status.
13. Automatic function menu key: Enter to select automatic massage program.
14. Remote function menu key: Enter to remotely set the massage function.
15. Seat adjustment menu key: Enter the sitting posture adjustment interface to select sitting posture angle.
16. Setting menu key: Enter the setting menu interface.

## Product structure

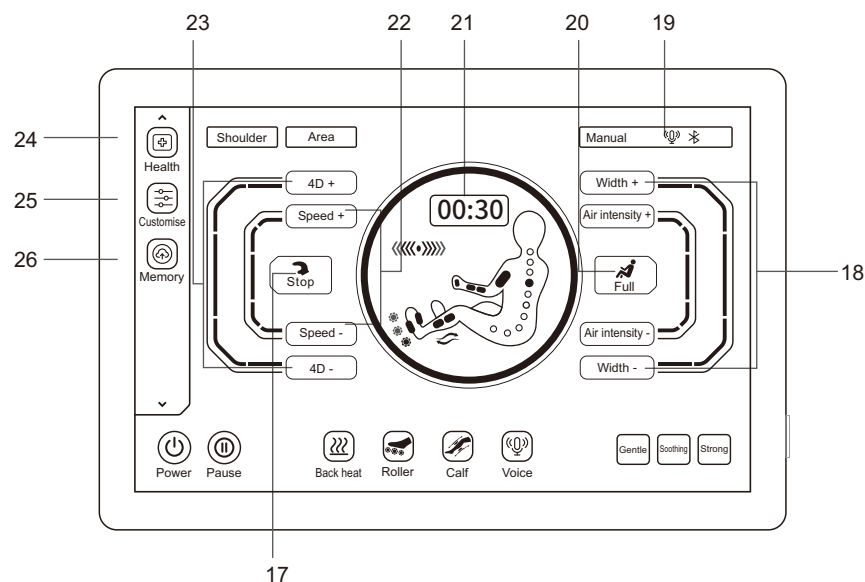

17. Massage technique selection key: Select the massage technique.
18. Massage width key: Adjust the massage width.
19. Status display bar key: Display the massage program status information.
20. Air message selection key: Select air position.
21. Time adjustment menu key: Adjust the massage time.
22. Massage speed key: Adjust the massage speed.
23. 4D intensity key: Adjust 4D intensity.
24. Health detection menu key: Enter the health detection interface.
25. Custom menu key: Enter the custom interface.
26. Storage menu key: Enter the storage interface.

## Product structure

### Description of armrest shortcut keys

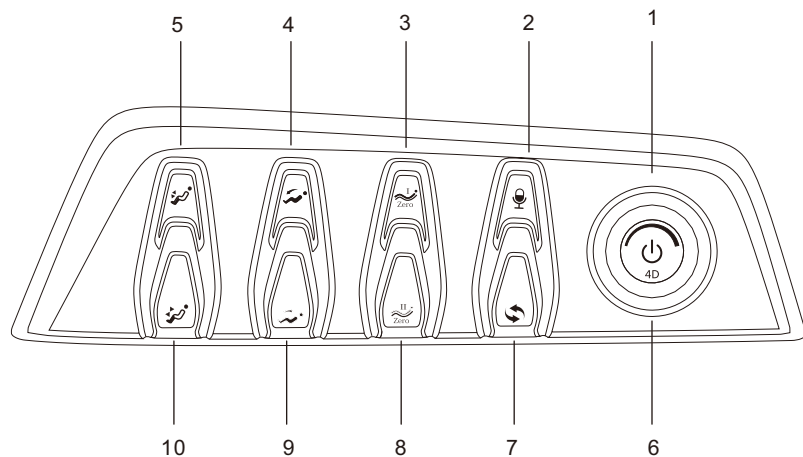

1. On/off key: Turn on or off the massage chair.
2. Voice key: Long press to turn on or off the voice assistant function. Short press to wake up the voice assistant function.
3. Zero-gravity key I: For zero-gravity angle setting, press this key to adjust the massage chair seat-down angle to zero-gravity key I position.
4. Linkage rising key: Adjust the massage chair angle upward.
5. Leg unit extension key: Leg unit stretching.
6. 4D intensity knob key: Turn the knob clockwise to enhance the 4D intensity Turn the knob counterclockwise to weaken the 4D intensity.
7. Automatic mode key: Automatic massage program switching.
8. Zero-gravity key II: For zero-gravity angle setting, press this key to adjust the massage chair seat-down angle to zero-gravity key II position.
9. Linkage lowering key: Adjust the massage chair angle downward.
10. Leg unit shrinkage key: Leg unit shortening.

## Operation Instructions

### I. Start massage

1. Press the remote controller side button on/off key or long press the armrest on/off key.
2. After the system is started, select the massage intensity by clicking on any one of the Gentle , Comfort or Strong keys on the remote controller to turn on the massage chair and enter the lying state. If it is not selected within 5 minutes, the massage chair will turn off automatically.

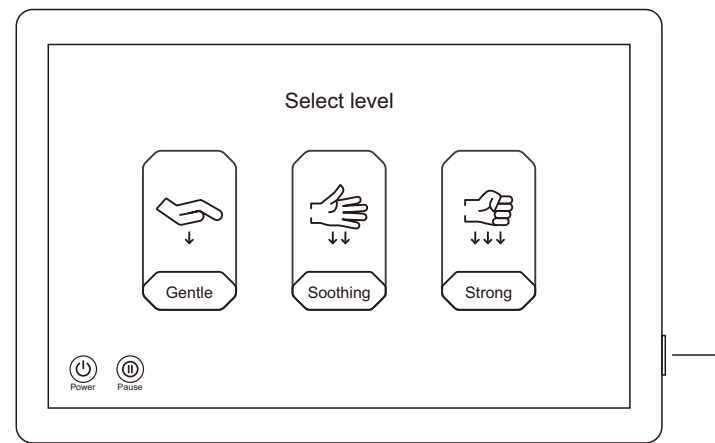

Button On/Off key, Press this key to turn the equipment on

3. For automatic angular adjustment, select the automatic program, then the massage chair will be automatically adjusted to zero-gravity angle, and wait until its adjustment is completed. To skip a step, press the skip key to go directly to the next step.

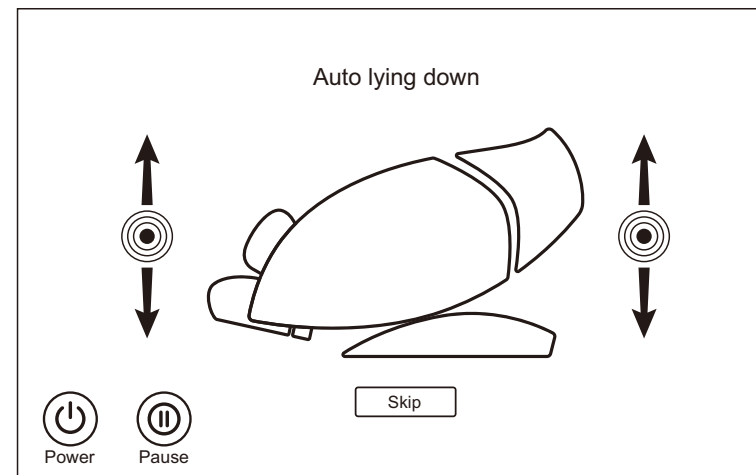

## Operation Instructions

4. Wait until body shape detection is completed, or you can press the skip key **Skip** to skip detection and start massage directly.

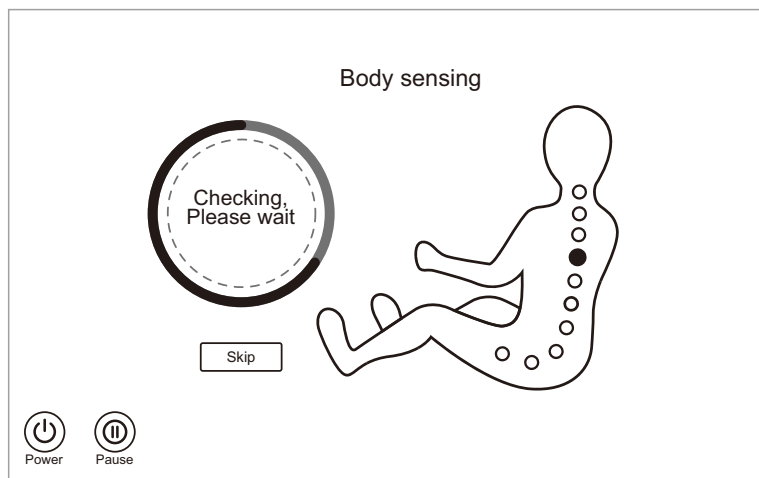

5. For fine adjustment of shoulder position, after body shape detection, the remote controller or a voice prompt will remind the user of fine adjustment of shoulder position. If the massage roller stops at the shoulder position, directly press the OK key **OK** to start massage. If not, use the Up key ▲ and Down key ▼ to adjust the massage roller to the shoulder position, and then press the OK key **OK** to start the massage. If no operation is made within 20s, directly default the current massage roller position for the shoulder position and start massage.

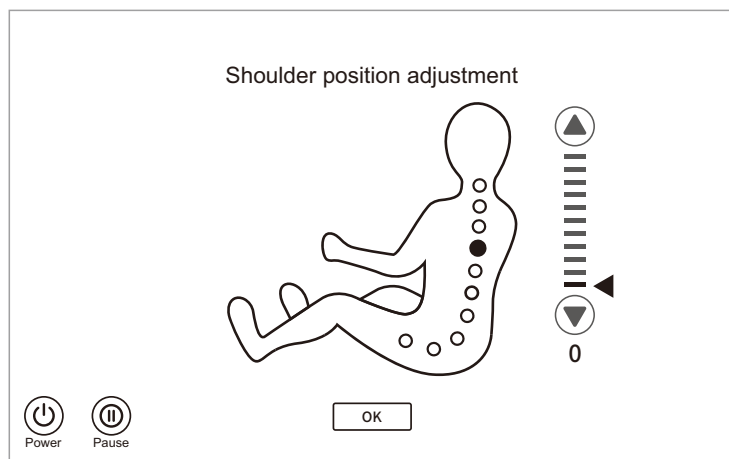

## Operation Instructions

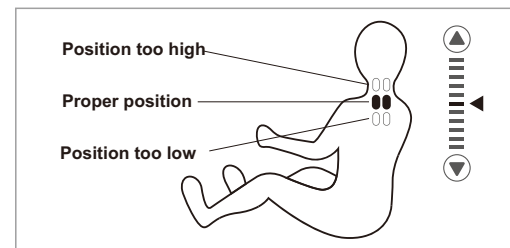

### II. Pause function (please use this function after the equipment is turned on)

After the massage chair is turned on, press the pause key **⏸** to enter the pause state, then all massage functions will be suspended, and press the pause key **⏪** again to resume the previous massage state. Note: In the pause state, all functions do not work except shutdown.

### III. Automatic program (please use this function after the equipment is turned on)

1. Automatic program selection: Select the Automatic key **⏸** in the left menu bar to enter the automatic selection interface.

- (1). In the automatic program selection interface, there are 20 automatic program options available: Total Relax, Chinese Massage, Relieve Muscle, Body Balance, Thai Massage, Full-body stretch, Neck & Shoulder Care, Hips&legs Fit, Spine Traction, Leg&foot Relieve, Superior Enjoyable, President Cosy, Keep Fit, Office Regimen, Health Recharge, Energy Boost, Lunch Break, Back Spa, Sport Recovery, Sweet Dream
- (2). Select the desired automatic massage program and click to start massage.

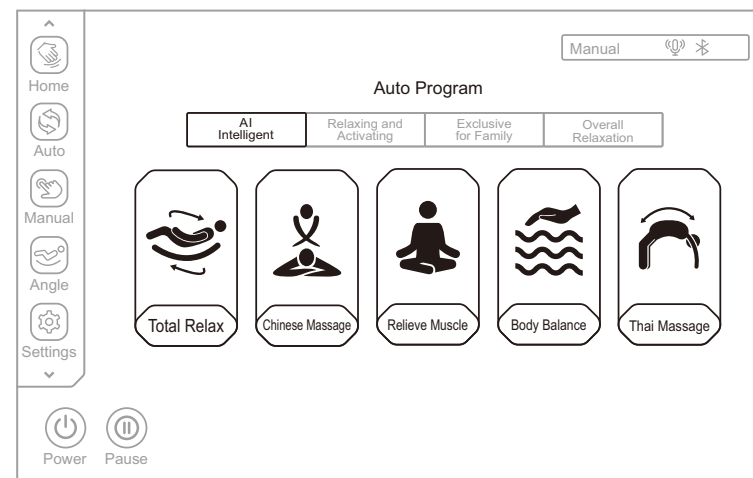

Schematic diagram of automatic massage program selection

## Operation Instructions

| Massage scenes(AI Intelligent) |  |
|--------------------------------|--|
| Function                       | Description  |
| Total Relax                    | With the aid of flexible guide rails, let the body posture angle closer to lying flat; with the effective anti-arch stretching of 3D movement to the back, achieve zero pressure stretching, effectively relieve lumbar muscle pain, and eliminate fatigue, thus to get a better massage experience, relieve the stress on the body and mind.  |
| Chinese Massage                | By means of Traditional Chinese medicine massage technique mainly, apply 3D massage on the back and waist so as to promote the blood circulation of the back and waist, soothe the meridians and relieve the blockage of the back and waist through massage. It is suitable for people with back and waist pain, and lumbar muscle strain. Massage intensity is gentle.                                    |
| Relieve Muscle                 | Apply deep pressure on the neck, back and waist, buttocks, and legs by means of kneading, patting, finger pressing techniques mainly to relieve the fatigue on body, allowing the body to better relax.  |
| Body Balance                   | Apply full air massage mainly, with the use of airbags for cross circulation of kneading and pressure, so as to promote blood circulation, alleviate pain in various body parts, and deeply relieve muscle fatigue. (Remarks: full air massage mainly, with frequent air massage action)   |
| Thai Massage                   | Mainly use calf and backrest electric push rod to clamp legs, hands and shoulders with the aid of air massage, and then apply stretching massage, while the movement holds against the back and waist for 3D medical massage, so that the body is in the Thai stretching state. It is suitable for people under high stress to improve their head-down on chest and humpback. Massage intensity is strong. |

## Operation Instructions

| Massage scenes(Relaxing and Activating) |   |
|---|---|
| Function                                | Description   |
| Full-body stretch                       | By means of kneading, patting, finger pressing and medical massage techniques mainly, clamp the legs, hands and shoulders with the aid of air massage, and then apply stretching massage to soothe the meridians, promote blood circulation, relieve blockages in the body.   |
| Neck & Shoulder Care                    | Massage the neck and shoulders by means of kneading and stretching techniques mainly, and also the upper back by medical massage, and then press the Jianjing acupoint to relieve cervical spondylosis and achieve the effect of relaxing the muscles of the neck and shoulders. Massage intensity is gentle, suitable for people working in office and suffering from cervical fatigue.  |
| Hips&legs Fit                           | Massage buttocks by kneading and medical massage mainly, and then through patting and kneading, deeply massage buttocks and perineum, to relax the hip muscles and lift the hip, which is suitable for women massage, and also for men for maintenance of prostate.   |
| Spine Traction                          | Massage the waist by means of kneading, patting and medical massage mainly, while the movement holds against the back and waist for 4D medical massage, so as to relieve lumbar spine pain; combined with the thermostatic heat configuration around the waist, maintain a comfortable temperature to bring warm massage experience; with gentle and moderate massage intensity and comfortable temperature, bring warm massage experience. |
| Leg&foot Relieve                        | Massage the shoulders and waist by means of kneading, patting, kneading and patting mainly, apply air massage on the legs and feet for squeezing massage, allowing more soothing leg and foot massage, suitable for sedentary people with low stress on the legs and feet, not only relieving the cervical spine, lumbar spine pain of sedentary people, but also soothing the legs and feet. Massage intensity is gentle.                  |

## Operation Instructions

| Massage scenes(Exclusive for Family) |   |
|--------------------------------------|---|
| Function                             | Description   |
| Superior Enjoyable                   | Apply air massage on the whole body, with the foot roller and calf kneading massage. Calf stretching function is canceled, suitable for the elderly and people suffering stress on back. The massage intensity is gentle.   |
| President Cosy                       | Massage the shoulders, neck, back and waist by means of kneading, patting, kneading and patting mainly, to relieve fatigue, promote blood circulation, and release stress by such deep massage. It is suitable for men, and the massage intensity is moderate.  |
| Keep Fit                             | Massage the shoulders, neck, waist and hips by means of kneading and finger pressing techniques, through the massage on the whole body, to relax the body and mind, and enjoy the queen-level treatment. It is suitable for women, and the massage intensity is gentle.   |
| Office Regimen                       | Massage the shoulders, neck and waist by means of kneading, patting, kneading and patting techniques mainly, to relieve shoulder and neck pain, improve lumbar muscle soreness and maintain lumbar spine through such deep massage. It is suitable for office white-collar and sedentary people, and the massage intensity is moderate. |
| Health Recharge                      | Deeply massage the whole body by means of kneading, patting and finger pressing techniques, to promote blood circulation throughout the body and prevent blood clots. It is suitable for people who live at home for a long time and do not like to go out, and the massage intensity is moderately gentle.                             |



## Operation Instructions

| Massage scenes(Overall Relaxation) |   |
|------------------------------------|---|
| Function                           | Description   |
| Energy Boost                       | Massage the waist, shoulders and neck by means of kneading, patting, kneading and patting techniques, to awaken the body's vital energy, stimulate physical energy through such deep massage of the whole body with the massage intensity being heavy, which is suitable for people with strong stress, such as athletes, for stimulating the potential before a race.  |
| Lunch Break                        | Massage the back and waist by means of kneading and patting techniques, and press the Shenyu acupoint, to improve the quality of lunch break, so that the user is more energetic in afternoon work. It is suitable for office workers, and the massage intensity is gentle.   |
| Back Spa                           | Deeply massage the whole body by pressing related acupoints by means of kneading, patting, finger pressing and other massage techniques, to let the stimulation fully reach the deep layer of muscle tissue, feel warm locally combined with the function of hot compress, and regulate the Qi and blood in a bid to achieve the effect of warmth and damp expelling. (Note: the whole body massage together with hot compress) |
| Sport Recovery                     | Massage the shoulders, neck and back and waist by means of kneading, patting and finger pressing techniques. At the same time, drag the calves to achieve the function of knee joint movement. Such deep massage can obtain the effect of exercise. It is suitable for people with less exercise, and the massage intensity is moderate.  |
| Sweet Dream                        | Massage the shoulders, neck, back and waist by means of kneading and medical massage techniques, and press the acupoints of Fengchi and Shenyu, to improve the sleep quality and help sleep. It is suitable for people suffering from poor sleep, and the massage intensity is gentle.  |

## Operation Instructions







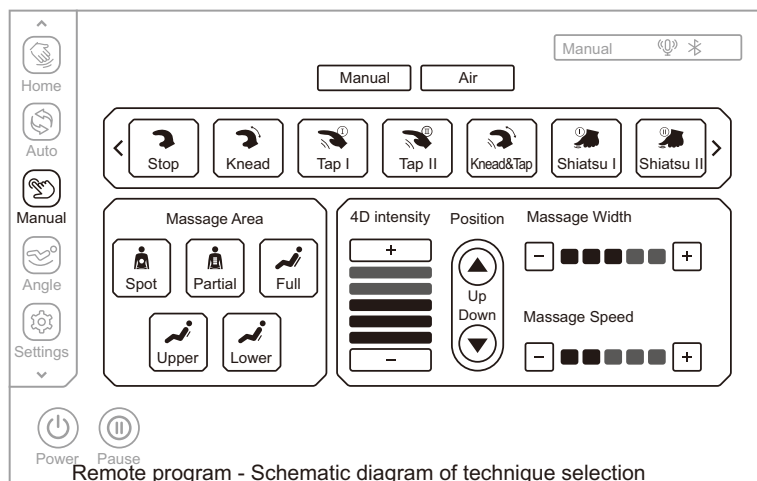



### IV. Remote program (please use this function after the equipment is turned on)

1. Remote program selection: Select the remote key  in the left menu bar and click to enter the remote menu to select message technique, message area, 4D intensity, message hand adjustment, message width, message speed, air massage, air intensity and other massage functions.



(1). In the message technique menu, a total of 11 options are available, including kneading, patting I, patting II, kneading and patting, finger pressing I, finger pressing II, shoulder grasp, 4DI, 4DII, 4DIII and 4DIV. (Note: Click the  leftward arrow and rightward arrow  button in the remote adjustment menu to scroll left and right to display more massage techniques).



Remote program - Schematic diagram of technique selection

| Function   | Message roller adjustment                        |                                    |
|--|--|------------------------------------|
| Stop   | Press this key to massage without any technique. |                                    |
| Knead       | The speed and strength can be adjusted.          | Adjustable speed in five gears     |
| Tap I       | The speed, width and strength can be adjusted.   |                                    |
| Tap II      | The speed, width and strength can be adjusted.   | Adjustable width in five gears     |
| Knead&Tap   | The speed and strength can be adjusted.          |                                    |
| Shiatsu I   | The speed, width and strength can be adjusted.   | Adjustable intensity in five gears |
| Shiatsu II  | The speed, width and strength can be adjusted.   |                                    |
| Grasp       | The speed and strength can be adjusted.          |                                    |
| 4D I        | Speed and strength can be adjusted.              |                                    |
| 4D II       | Speed and strength can be adjusted.              |                                    |
| 4D III      | Speed, width and strength can be adjusted.       |                                    |
| 4D IV       | Speed, width and strength.                       |                                    |

## Operation Instructions

Note: In the "Home  " interface, you can also click the message technique key  select the corresponding message technique in the pop-up menu for massage (this function is a shortcut for switching message techniques in the current status page of the remote program - technique adjustment).

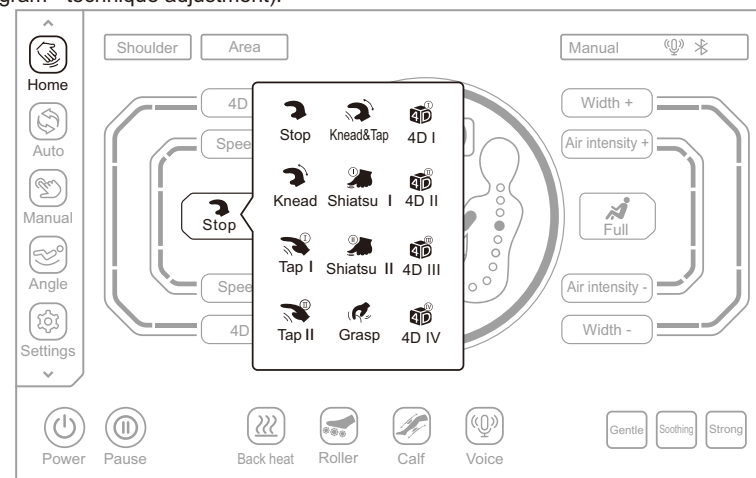



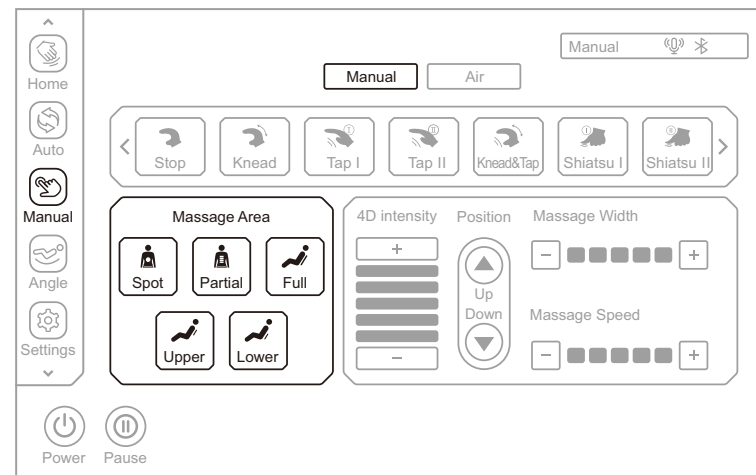

Current Status - Schematic diagram of technique selection

2. The message area menu has five options: Spot, Partial, Full, Upper and Lower. Select the corresponding message area for massage.



Remote program - Schematic diagram of message area selection

## Operation Instructions

| Key   | Description                                  |
|---|--|
|  | Fixed-point massage at fixed-point position. |
|  | Small-scope local massage back and forth.    |
|  | Full back massage back and forth.            |
|  | Upper back massage back and forth.           |
|  | Lower back massage back and forth.           |

Note: In the “Home”  interface, you can also click the massage area key **Area** to select the corresponding massage area in the pop-up menu for massage (this function is a shortcut for switching massage areas in the current status page of the remote program - massage area).

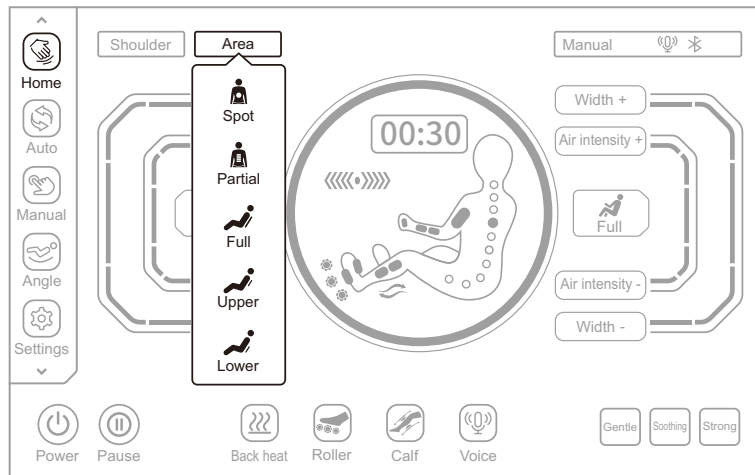

Current Status - Schematic diagram of massage area selection

## Operation Instructions

3. You can adjust 4D intensity in the 4D intensity menu. There are 1~5 gears available for adjustment with 1 being the weakest and 5 being the strongest. The stronger the 4D intensity, the higher the massage roller ejection and the greater the massage strength. Select plus key **+** or minus key **-** to reduce the 4D intensity.

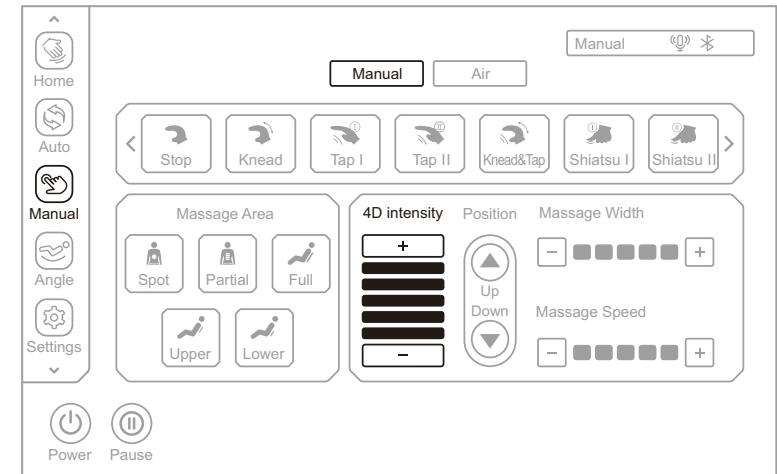

Remote program - Schematic diagram of 4D intensity

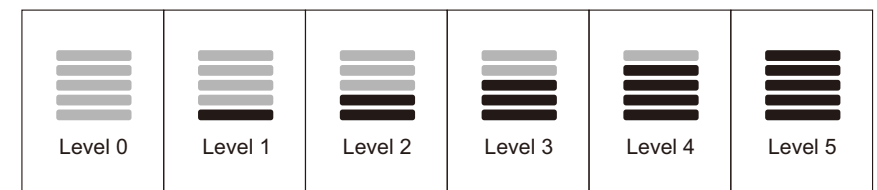

| Key      | Description  |
|----------|--|
| <b>+</b> | Press this key to increase 4D intensity which is adjustable from 1 to 5. |
| <b>-</b> | Press this key to decrease 4D intensity which is adjustable from 1 to 5. |

## Operation Instructions

Note: In the “Home” interface, you can also select the 4D intensity + **4D +** key or 4D intensity - **4D -** key to adjust the 4D intensity. (This function is a shortcut to the 4D intensity in the current status page of the remote program-4D intensity).

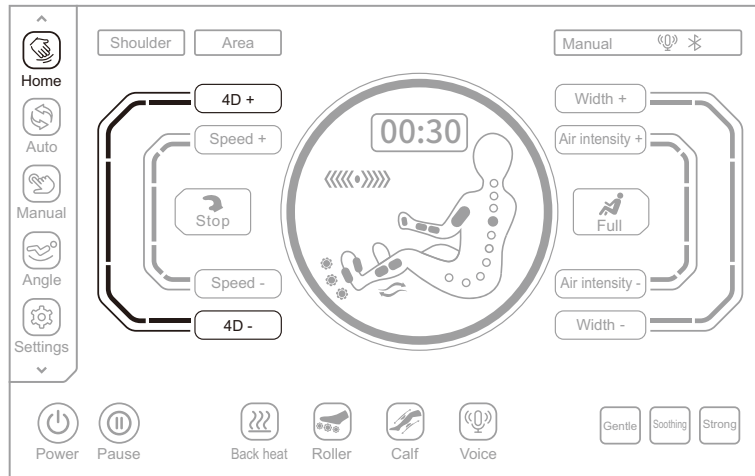

Current Status - remote program-4D intensity



| Key         | Description  |
|-------------|--|
| <b>4D +</b> | Press this key to increase 4D intensity which is adjustable from 1 to 5. |
| <b>4D -</b> | Press this key to decrease 4D intensity which is adjustable from 1 to 5. |

## Operation Instructions

4. For message hand adjustment, select the Up arrow or the Down arrow down to upwards or downwards fine-adjust the message hand position.

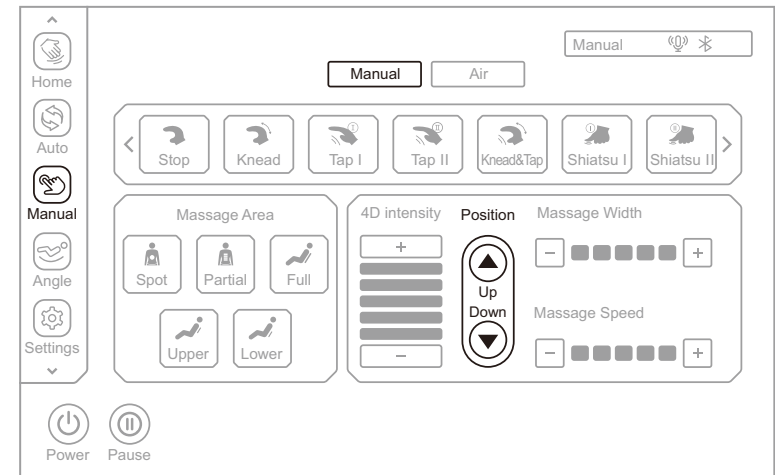

Remote program - Schematic diagram of message hand adjustment

5. For message width, as shown in the figure below, select the message width to adjust.

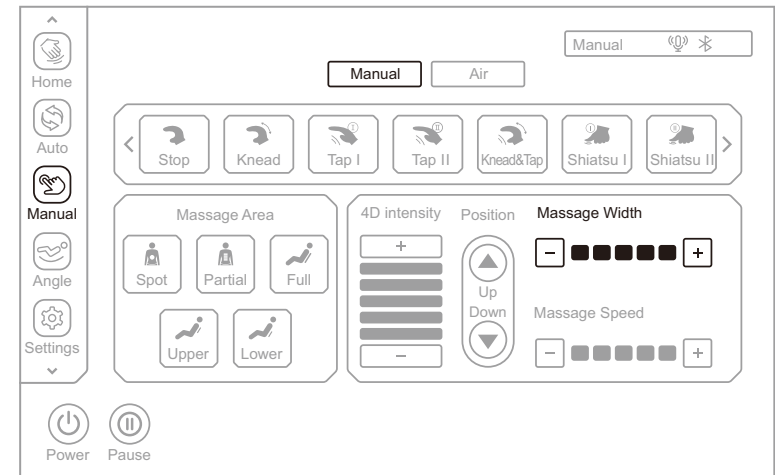

Remote program - Schematic diagram of message width

## Operation Instructions

- The width can be adjusted only when the user enters the remote mode in selecting message technique or message area.
- The message width is available from 1 to 5 gears, with 1 being the narrowest and 5 being the widest. Please use the following message techniques: PattingI, PattingII, Finger PressingI, Finger Pressing II, 4D III and 4D IV.

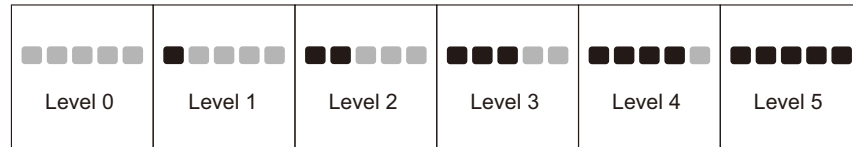

| Key | Description   |
|-----|---|
|     | Press this key to increase message width which is adjustable from 1 to 5. |
|     | Press this key to decrease message width which is adjustable from 1 to 5. |

Note: In the “Home” interface, you can also select the message “width + ” key or message “width - ” key to adjust the message width.

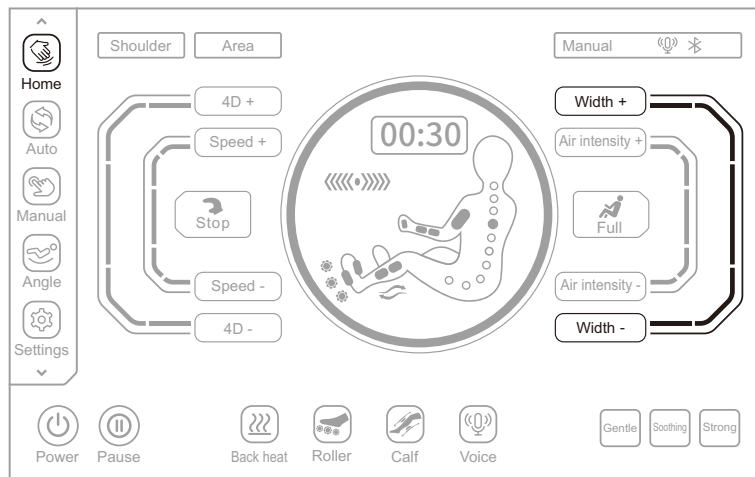

Current Status - Schematic diagram of message width

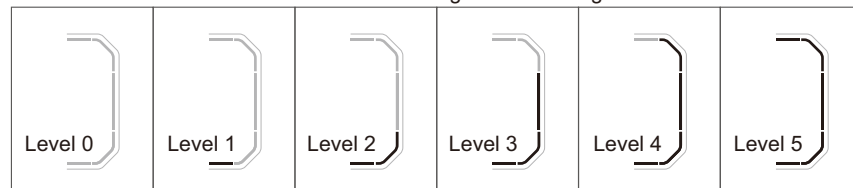

## Operation Instructions

| Key | Description   |
|-----|---|
|     | Press this key to increase message width which is adjustable from 1 to 5. |
|     | Press this key to decrease message width which is adjustable from 1 to 5. |

- For message speed, as shown in the figure below, select the message speed to adjust.

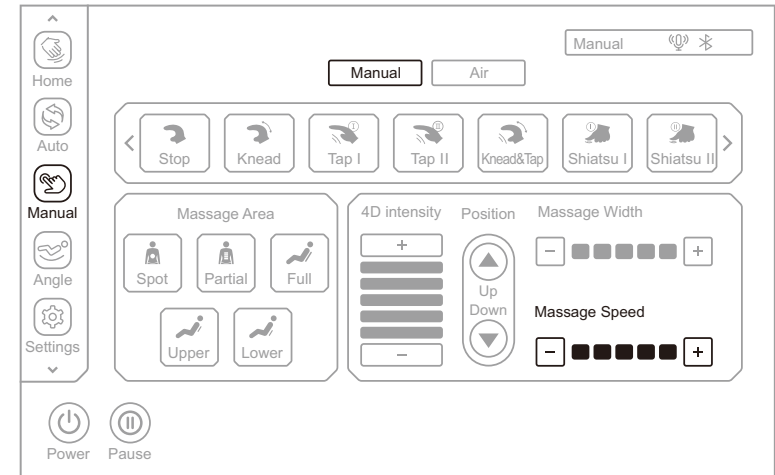

Remote program - Schematic diagram of message speed

- The speed can be adjusted only when the user enters the remote mode in selecting message technique or message position.
- The message speed is available from 1 to 5 gears, with 1 being the fastest and 5 being the slowest. The speed cannot be adjusted when the message technique stops.

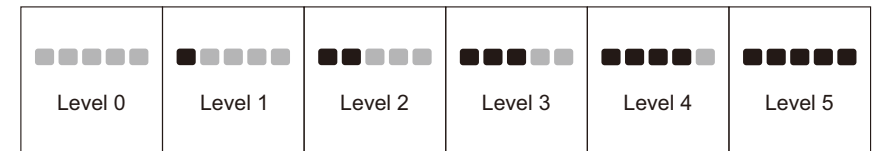

| Key | Description   |
|-----|---|
|     | Press this key to increase message speed which is adjustable from 1 to 5. |
|     | Press this key to decrease message speed which is adjustable from 1 to 5. |

## Operation Instructions

Note: In the “Home” interface, you can also select the massage speed + **Speed +** key or massage speed - **Speed -** adjust the massage speed.

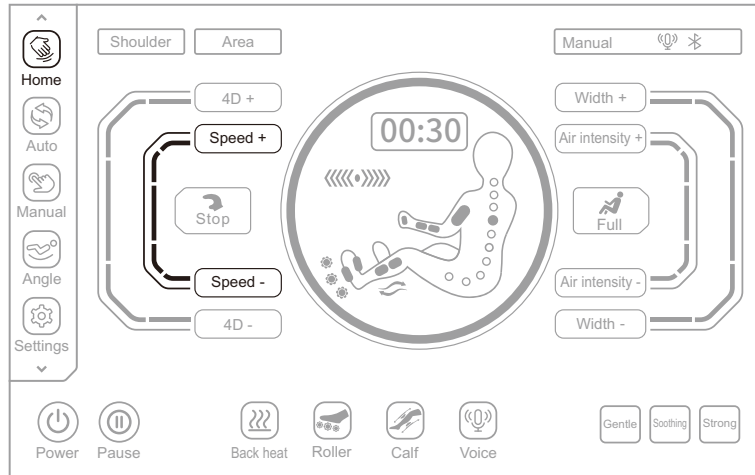

Current Status - Schematic diagram of massage speed



| Key            | Description   |
|----------------|---|
| <b>Speed +</b> | Press this key to increase massage speed which is adjustable from 1 to 5. |
| <b>Speed -</b> | Press this key to decrease massage speed which is adjustable from 1 to 5. |

## Operation Instructions

7. For air massage, as shown in the figure below, enter the air massage menu to select the air mode. The air modes include upper body, lower body, and whole body air massage. The air function will be disabled when all above modes are off.

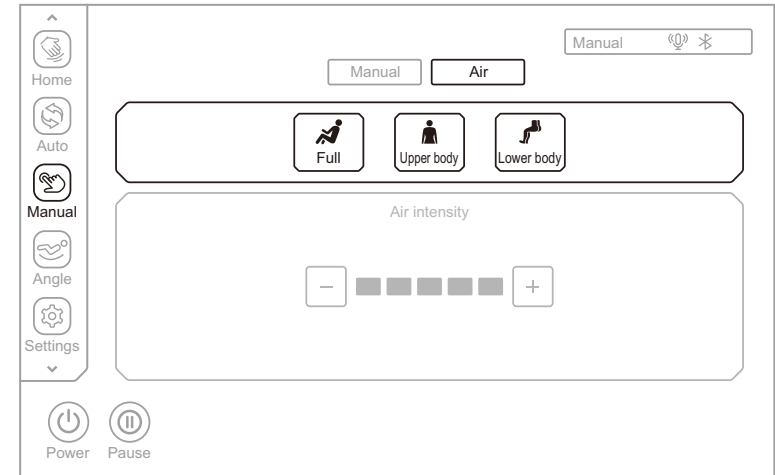

Remote program-Schematic diagram of air massage

| Key | Description  |
|-----|--|
|     | Press this key to enable or disable the whole body air massage function. |
|     | Press this key to enable or disable the upper body air massage function. |
|     | Press this key to enable or disable the lower body air massage function. |

| Air pressure display    |                         |                         |
|-------------------------|-------------------------|-------------------------|
| Upper body air pressure | Lower body air pressure | Whole body air pressure |
|                         |                         |                         |

## Operation Instructions

Note: In the "Home" interface, you press also air massage key and select corresponding air mode in the pop-up menu. (This function is a shortcut to the air massage in the current status interface of the remote function - air massage.)

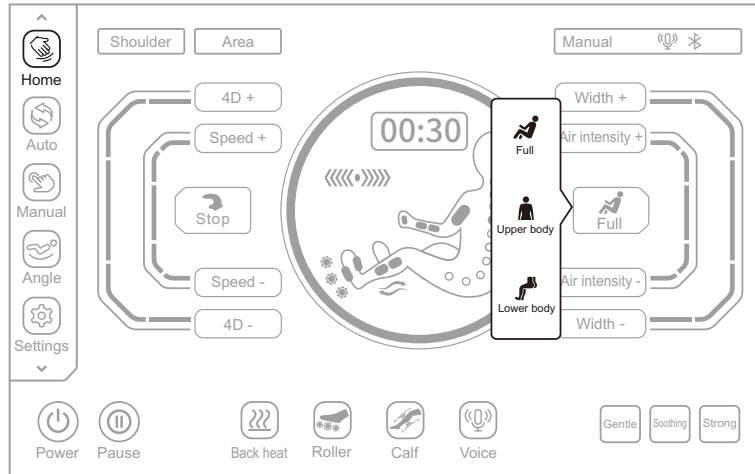

Current status - Schematic diagram of air massage

8. For air intensity adjustment, the air function shall be turned on so as to adjust the air intensity, with a total of five adjustable levels, with 1 being the weakest and 5 being the strongest.

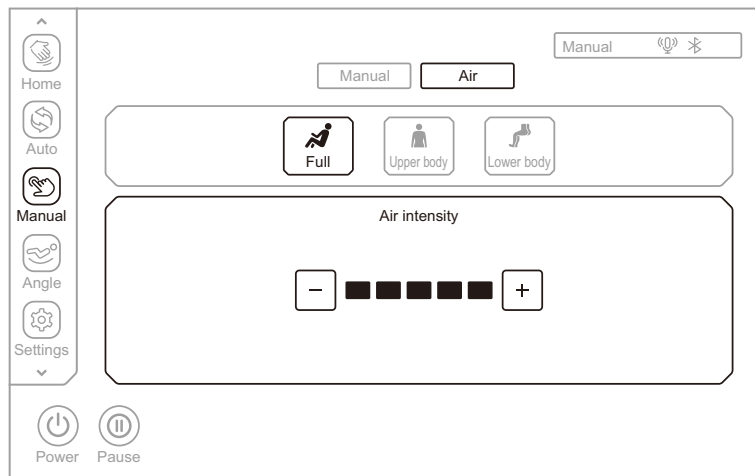

## Operation Instructions

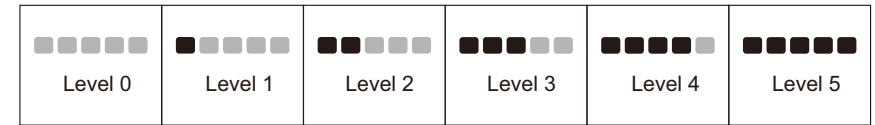

| Key | Description   |
|-----|---|
|     | Press this key to increase the air intensity which is adjustable from 1 to 5. |
|     | Press this key to decrease the air intensity which is adjustable from 1 to 5. |

Note: In the "Home" interface, you can also adjust the air intensity by selecting the air intensity+ key or air intensity- key with the adjustable intensity in five levels.

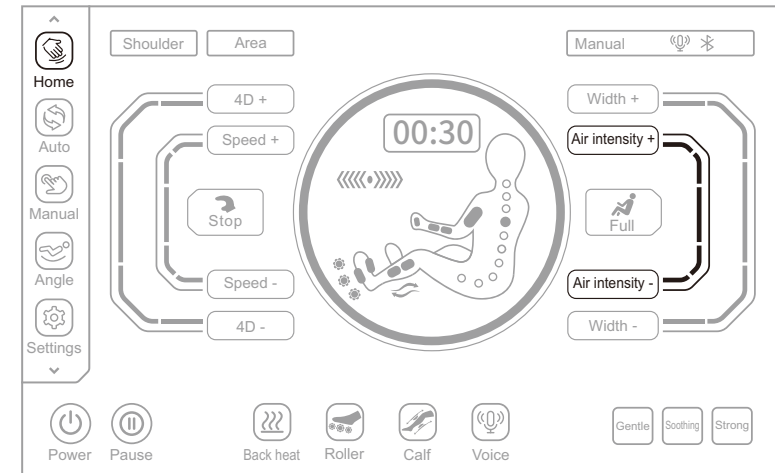

Current status - Schematic diagram of air intensity

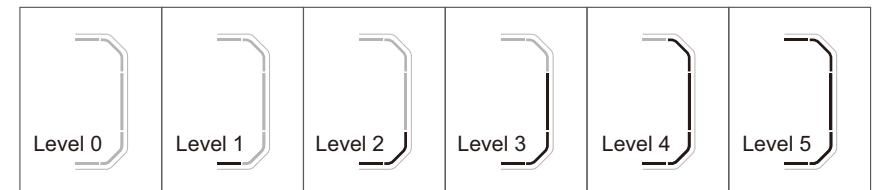

| Key | Description   |
|-----|---|
|     | Press this key to increase the air intensity which is adjustable from 1 to 5. |
|     | Press this key to decrease the air intensity which is adjustable from 1 to 5. |

## Operation Instructions

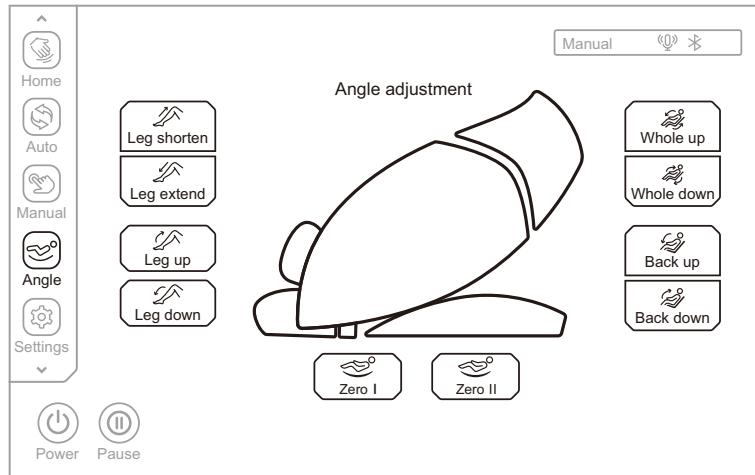

### V. Seat adjustment

Click the "Angle  " button in the menu bar on the left side of the display to enter the Seat Adjustment interface, with massage functions including leg unit extension/shortening, leg unit Up/Down, linkage Up/Down, zero-gravity I and II .





Schematic diagram of sitting posture adjustment

#### 1.Zero-gravity adjustment



| Key  | Description   |
|--|---|
| <br>Zero I    | Zero-gravity 1 key: automatically adjust the position of leg unit and backrest unit to zero-gravity 1 position.   |
| <br>Zero II | Zero-gravity II key: automatically adjust the position of leg unit and backrest unit to zero-gravity II position. |

#### 2. Seat-down angular adjustment



| Key   | Description  |
|---|--|
| <br>Leg up   | Leg unit Up key: press and hold this key to slowly raise the leg unit, and release it to stop rising; after the leg unit rising action is completed, the leg unit will automatically detect the foot length.       |
| <br>Leg down | Leg unit Down key: press and hold this key to slowly lower the leg unit, and release it to stop lowering; after the leg unit lowering action is completed, the leg unit will automatically detect the foot length. |

## Operation Instructions



#### 3.Linkage unit angular adjustment

| Key   | Description   |
|---|---|
| <br>Whole up   | Linkage Up key: press and hold this key to slowly raise the backrest unit while slowly lowering the leg unit, and release it to stop raising the backrest unit or lowering the leg unit; after the linkage rising action is completed, the leg unit will automatically detect the body height.    |
| <br>Whole down | Linkage Down key: press and hold this key to slowly lower the backrest unit while slowly raising the leg unit, and release it to stop lowering the backrest unit or raising the leg unit; after the linkage lowering action is completed, the leg unit will automatically detect the body height. |

#### 4.Backrest unit angular adjustment

| Key  | Description  |
|--|--|
| <br>Back up   | Backrest unit Up key: press and hold this key to slowly raise the backrest unit and release it to stop rising.     |
| <br>Back down | Backrest unit Down key: press and hold this key to slowly lower the backrest unit and release it to stop lowering. |

#### 5.Leg unit extension/shortening adjustment

| Key   | Description   |
|---|---|
| <br>Leg shorten  | Leg unit shortening key: remotely adjust shortening of the leg unit; press and hold this key to move the leg unit up slowly and stop when released. |
| <br>Leg extend | Leg unit extension key: remotely adjust extension of the leg unit; press and hold this key to move the leg unit down slowly and stop when released. |

## Operation Instructions

### VI. Setting (please use this function after the equipment is turned on)

Click the "Setting"  button in the menu bar on the left side of the display to enter the setting interface, where you can view the product model, software version number, product serial number, and firmware version number. In the interface, functions such as Bluetooth, voice control, voice broadcast, language selection, volume, and ambient lighting control are available for setting.

- 1.Product model, software version, product serial number, and firmware version show the information of current device.
- 2.Bluetooth(Operation Instructions for Bluetooth Speaker Play)
  - (1).Click the "Bluetooth" switch to turn the Bluetooth function on or off. After you turn on the Bluetooth function, you can connect the audio device with Bluetooth to the massage chair. (such as mobile phone, MID tablet, etc.) with the Bluetooth module of the massage chair, the music played by the sound source device can be wirelessly transmitted to the sound system of the massage chair through Bluetooth for music playing.
  - (2).Enter the smart device main menu. Open "Settings" and select the "Bluetooth" option. Open "Bluetooth", and Bluetooth will automatically "Search for a New Bluetooth Device".
  - (3).The smart device will search for the corresponding Bluetooth model (e.g. IMCM-XXXX). Click the "Match" button. If you are asked whether to match with the device, you just select "Match" to complete matching.
  - (4).Turn on "Music Player" in the smart device and select the song to play.

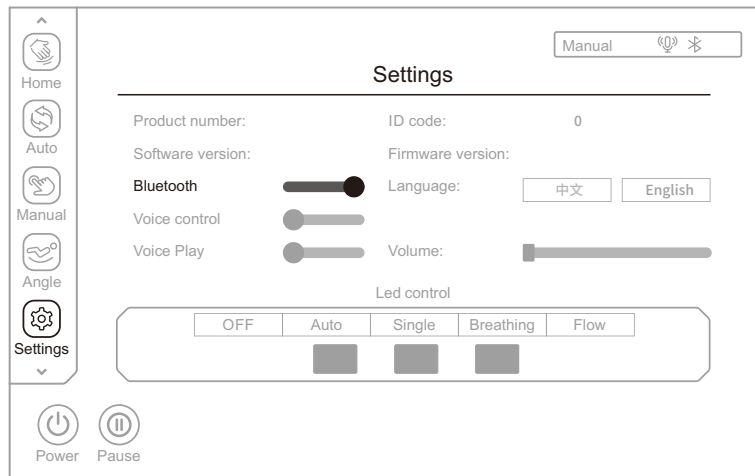

Schematic diagram of Setting

## Operation Instructions

- 3.Language selection: After entering the settings interface as shown in the figure below, choose different languages according to the user's needs. The default language is English, and Chinese is optional.

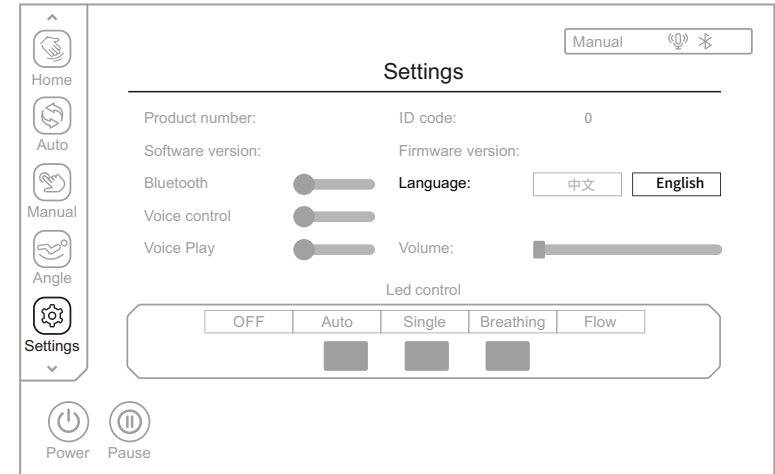

- 4.Voice Control: Click Voice Control switch to enable or disable the Voice Control function.After enabling the voice function, you can control the massage chair by voice according to the content of the voice entry.

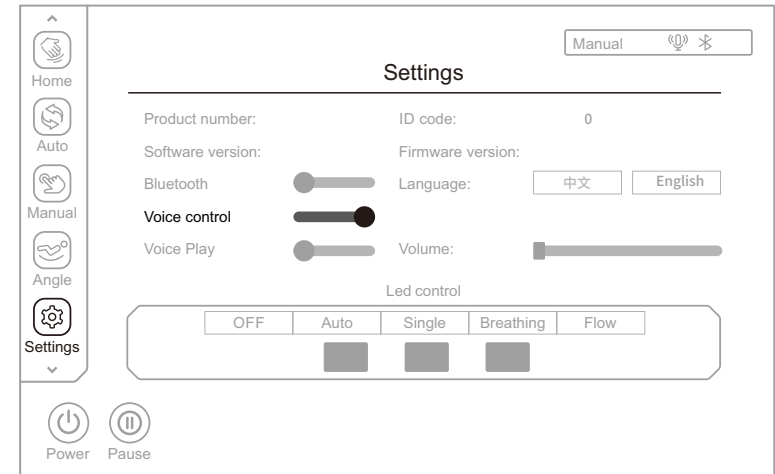

## Operation Instructions

- (1). In the massage chair open state, and need to confirm whether the voice control function is open (if not, please enter the setting interface to open it first); When voice control is open, you can press the "Voice control key" on remote controller, or you near the speaker to "Hi Alice" or "Hey Alice" to wake up the voice assistant, when the voice assistant replies "I'm here", it represents that it has been woken up, and after opening the voice control assistant, you can use the voice control assistant function to control the massage chair.
- (2). You can also short press the "Voice key" button in the armrest shortcut key to wake up the voice assistant, and long press and hold this key for 3 seconds to turn it on or off.
- (3). After the voice assistant wakes up, please say the command within 6 seconds to realize the function control of the Massage chair. After the voice assistant responds to the command, you can continue to say the command. The interval between two adjacent commands cannot exceed 6 seconds, otherwise you need to wake up the voice assistant again. The detailed voice command table is as follows:

Attention: When awakening the voice control function, the speaking speed should not be too fast, and voice commands should be issued according to Voice Control Entry.

| Voice Control Entry                                  |                        |                                    |
|--|------------------------|------------------------------------|
| Entry: "Hi Alice" or "Hey Alice". Answer: I am here. |                        |                                    |
| No.  | Voice control entry    | Answer entry                       |
| 1  | Massage on             | Answer: Ok, Massage on             |
| 2  | Massage close          | Answer: Ok, Massage close          |
| 3  | Total Relax            | Answer: Ok, Total Relax            |
| 4  | Energy Boost           | Answer: Ok, Energy Boost           |
| 5  | Sweet Dream            | Answer: Ok, Sweet Dream            |
| 6  | Neck & Shoulder Care   | Answer: Ok, Neck & Shoulder Care   |
| 7  | Lunch Break            | Answer: Ok, Lunch Break            |
| 8  | Thai Massage           | Answer: Ok, Thai Massage           |
| 9  | Open the air pressure  | Answer: Ok, Open the air pressure  |
| 10   | Close the air pressure | Answer: Ok, Close the air pressure |
| 11   | Up the seat position   | Answer: Ok, Up the seat position   |
| 12   | Down the seat position | Answer: Ok, Down the seat position |
| 13   | Change the other mode  | Answer: Ok, Change the other mode  |
| 14   | Go little down         | Answer: Ok, Go little down         |
| 15   | Go little up           | Answer: Ok, Go little up           |

Note: commands 14 and 15 can only be used after command 13.

## Operation Instructions

5. Voice Play: After clicking the "Voice Play" switch and enabling the Voice Play function, the user will be reminded how to use the massage chair correctly in use of the massage chair to help a new user become familiar with the massage functions faster.

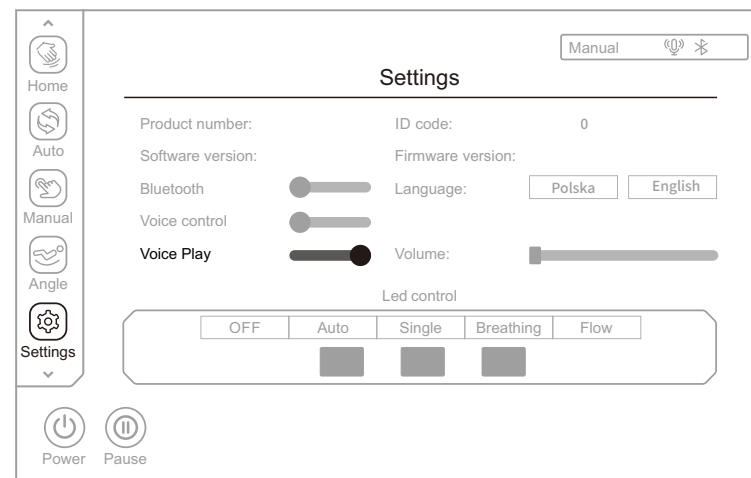

6. Volume: Select the volume slider and slide it left or right to adjust the volume level with 10 being the maximum.

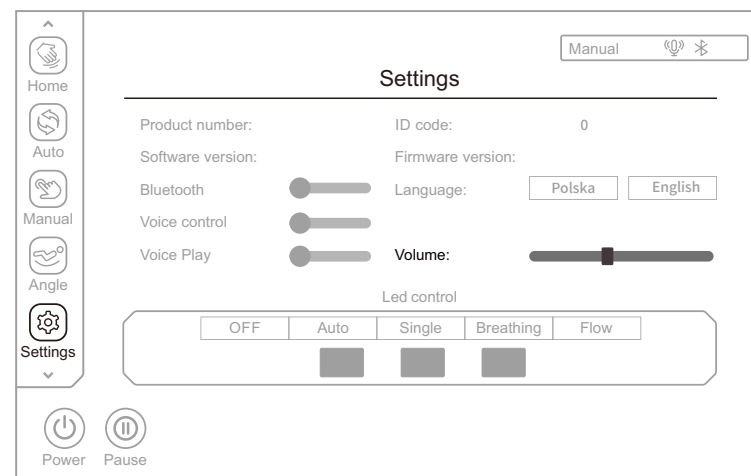

## Operation Instructions

7. Ambient lighting control: Ambient lighting mode setting. The functions for setting include OFF, automatic mode, monochrome mode, breathing mode, flow mode, etc. Please set them according to your own preferences.

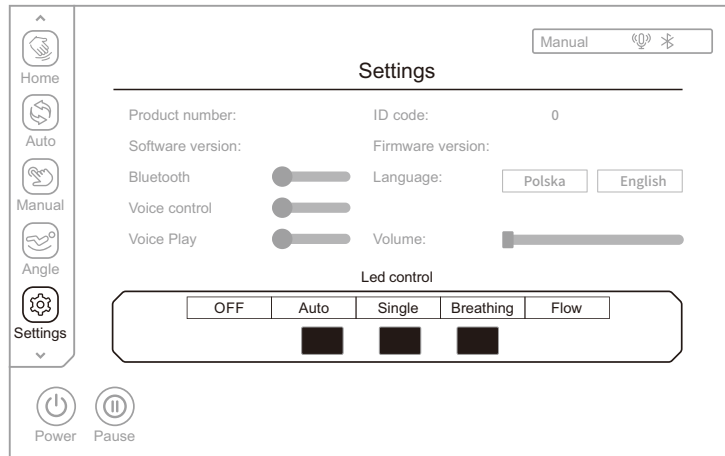

### VII. Health detection (please use this function after the equipment is turned on)

1. Click the "Health" key in the menu bar on the left side of the display to enter the health detection interface, and press the Start Detection key **Start** to start the health detection. After entering the health detection state, gently place the index finger or middle finger on the sensor and wait for the end of the detection.



## Operation Instructions

### Health check progress indicator

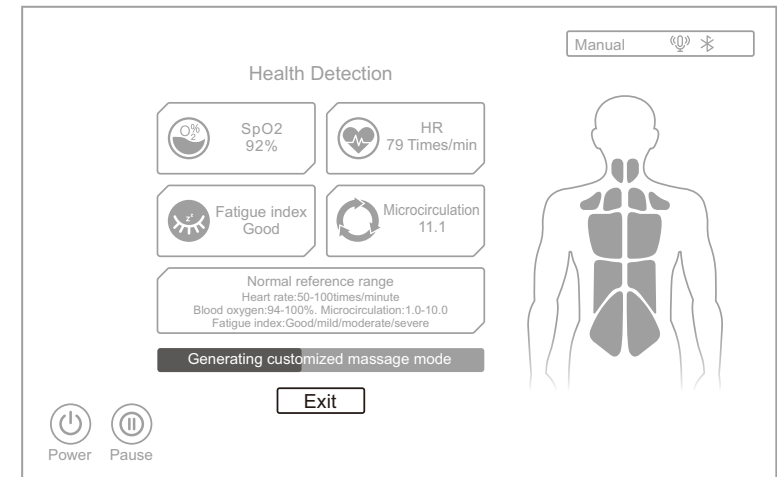

2. Recommended program: When normal detection is completed, it will display the heart rate, blood oxygen, and the fatigue level, respectively. The blood oxygen means with the blood oxygen concentration ranging from 95% to 99% normally. The fatigue levels include Good, Mild, Moderate and Severe. Based on your fatigue level, an automatic program will be recommended for you. Select "Yes" to start using the recommended program and "No" to return to the massage state before the health detection.

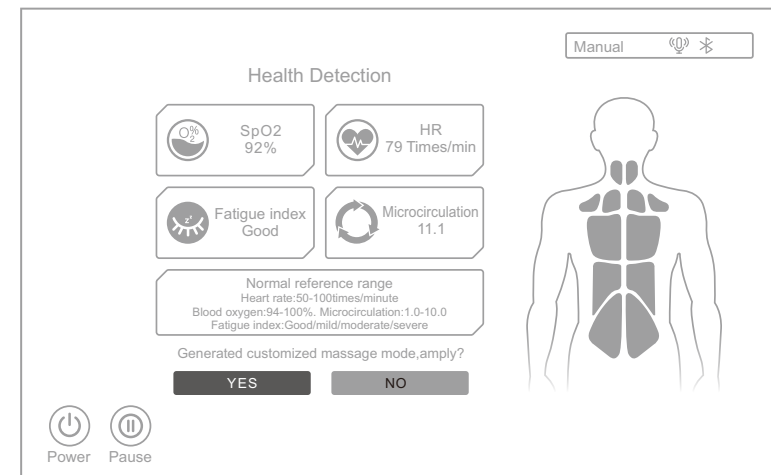

## Operation Instructions

3.No valid data is detected: If no valid data is detected, the user will be prompted to ask whether to re-detect. Select "Yes" to restart the health detection, and "No" to exit the detection and return to the massage state before the health detection.



4.Exit health detection: During health detection, press the **Exit** key to exit the detection and return to the massage state before the health detection.

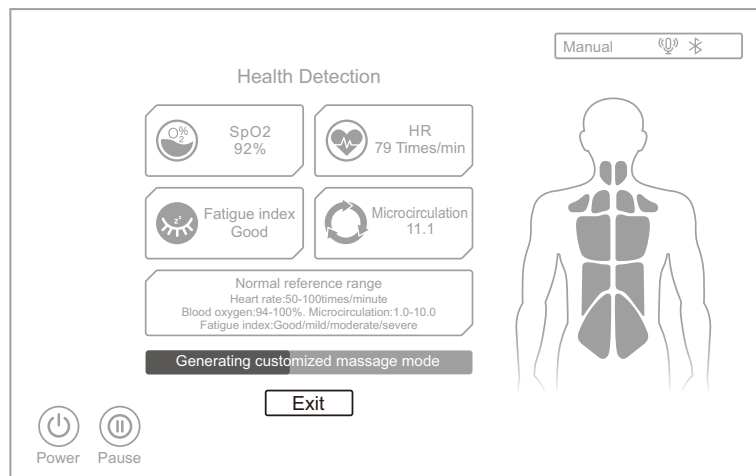

## Operation Instructions

### VIII.Custom (please use this function after the equipment is turned on)

Click the "Custom" key in the menu bar on the left side of the display to enter the custom setting interface and select either Custom I or Custom II (only if the corresponding custom has been previously set and saved) for massage.

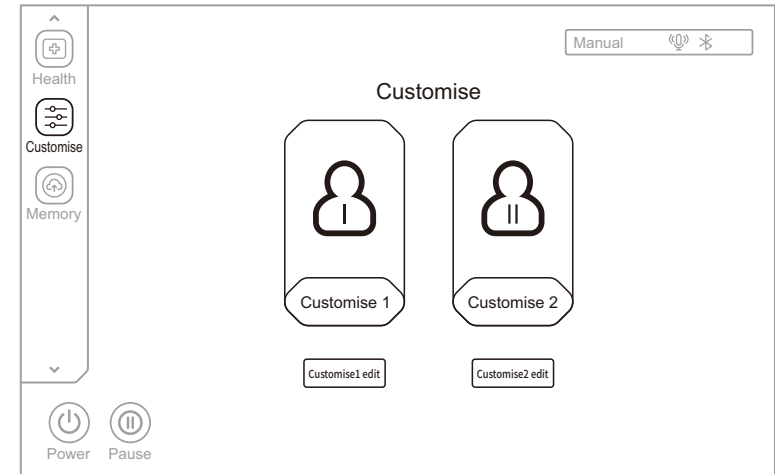

Schematic diagram of Custom

Click Custom I Setting or Custom II Setting to enter the Custom Setting interface, then select the preferred massage technique whose icon will be highlighted after selection, and select the massage interval, 4D intensity, air massage, massage width, massage speed, air intensity, back heating, calf kneading and other functions, then click Save to save the current settings as Custom I and Custom II. After the settings are saved successfully, the custom program will be immediately available and can be used for the next massage by clicking the saved custom program.

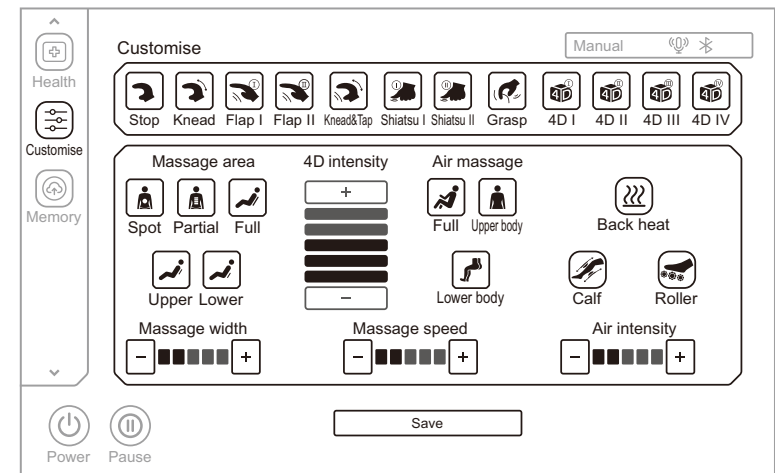



## Operation Instructions

### IX.Storage (please use this function after the equipment is turned on)

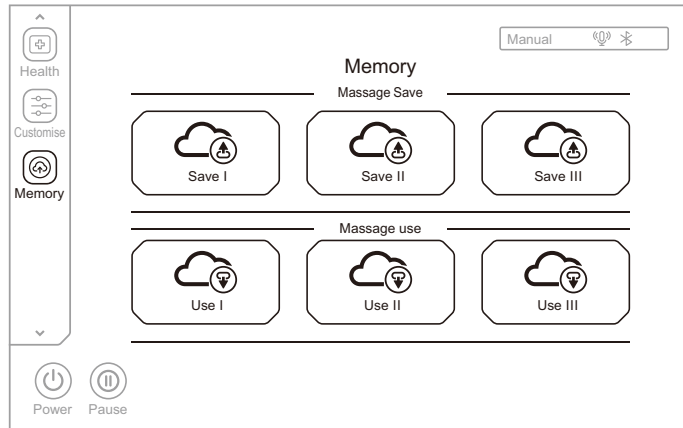

Click the "Memory"  key in the menu bar on the left side of the display to enter the message function storage selection interface, with two categories including message function storage and message function call. Message storage includes: Save I, Save II and Save III. Message Use includes: Use I, Use II and Use III.





| Key   | Description  |
|---|--|
|    | Save: Saving the currently running message program, including automatic program, message technique, air mode and intensity, position and angle of leg unit and backrest unit, and other message functions. |
|  | Use: Calling the previously saved message program, including automatic program, message technique, air mode and intensity, position and angle of leg unit and backrest unit, and other message functions.  |

## Operation Instructions

### X. Other functions (please use this function after the chair is turned on)

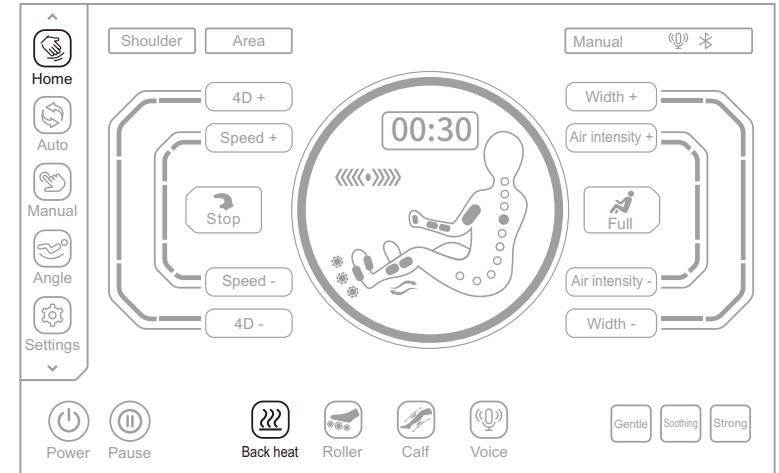
In addition to setting in the Custom interface, the function can also be enabled or disabled by selecting the In the "Home"  interface, select the "Back Heating"  key to turn on or off the shawl heating function. There will be warmth after turning on the heating function for 3 minutes



In addition to setting in the Custom interface, the function can also be enabled or disabled by selecting the In the "Home"  interface, click the "Roller"  button to turn on or off the foot roller message function, with three adjustable speeds. Press it for the first time to start Level 1 speed; press it for the second time to start the Level 2 speed; press it for the third time to start the Level 3 speed; and press it for the fourth time to disable the Sole Roller function, which are switched cyclically.

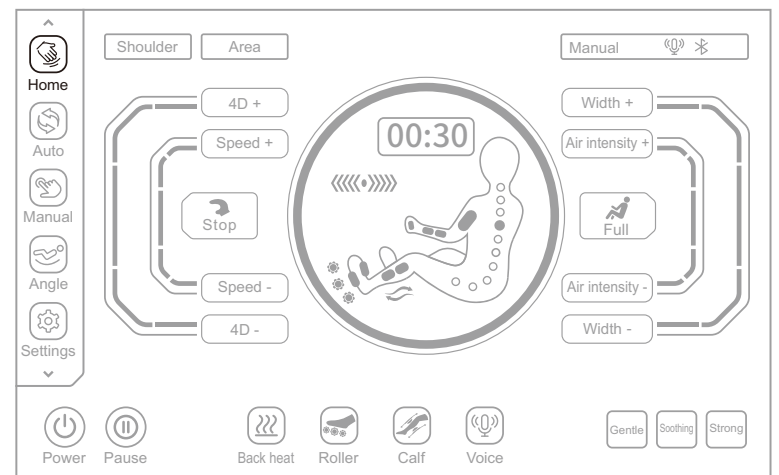

## Operation Instructions

In addition to setting in the Custom interface, the function can also be enabled or disabled by selecting the In the "Home" interface, select the "Calf" button to turn on or off the calf rubbing massage function; in The inner side of the calf is provided with rubbing massage function, and the outer side is provided with airbag squeeze massage function, which can relieve the calf muscle stiffness or tension caused by long standing.

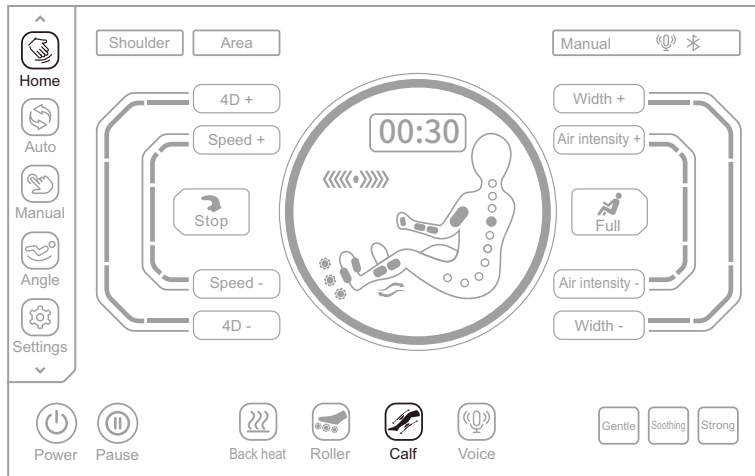

In addition to setting in the Custom interface, the function can also be enabled or disabled by selecting the In the "Home" interface, select the "Voice" key to wake up the voice assistant.

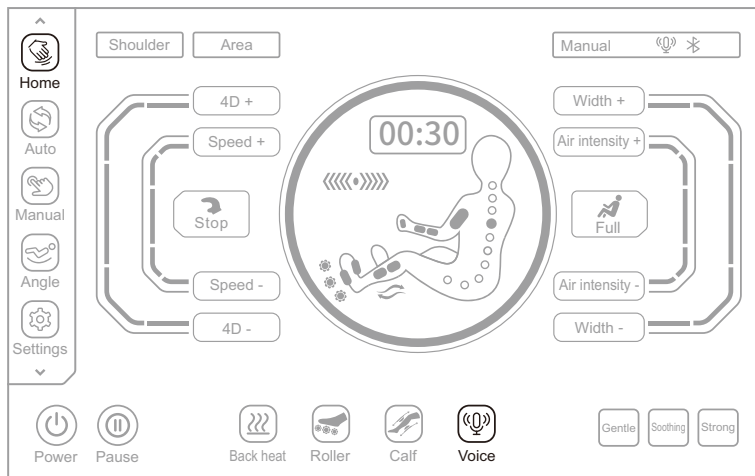

## Operation Instructions

In addition to setting in the Custom interface, the function can also be enabled or disabled by selecting the In the "Home" interface, select the "Shoulder Position Adjustment" button, and press the up and down arrow buttons in the pop-up menu to adjust the shoulder position, with a total of 11 adjustable levels.

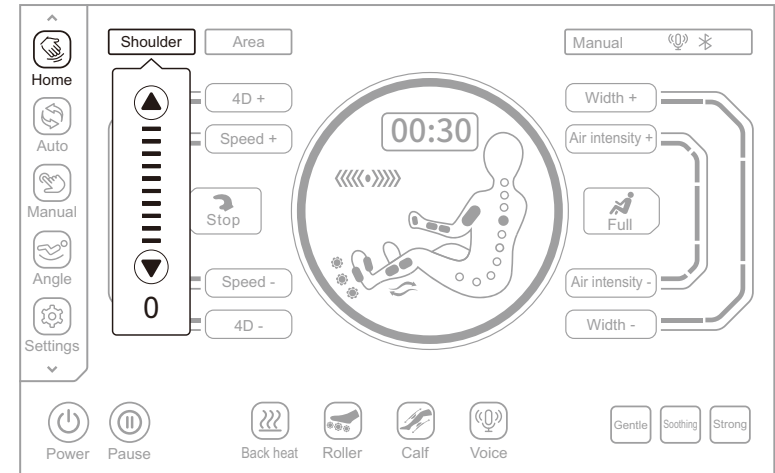

In addition to setting in the Custom interface, the function can also be enabled or disabled by selecting the In the "Home" interface, select the "message time adjustment" button, press the plus and minus arrow head button in the pop-up menu, you can increase or decrease the massage time. Click the "+" key, the time increased by 5 minutes, the maximum increase to 40 minutes. Click the "-" key, the time decreased by 5 minutes.

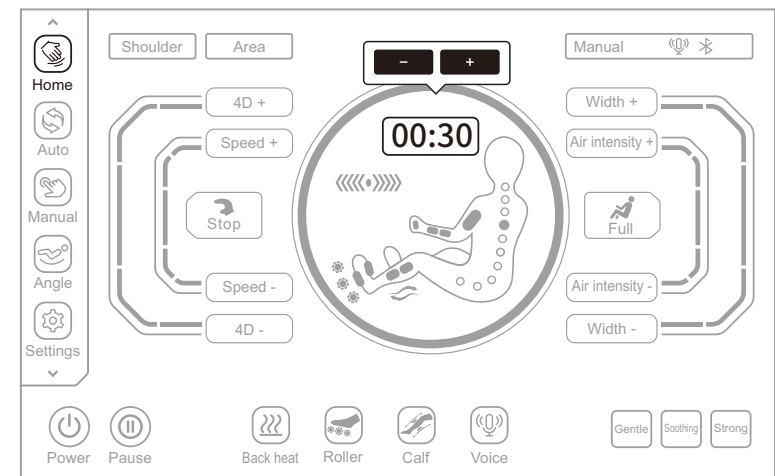

## Operation Instructions

In addition to setting in the Custom interface, the function can also be enabled or disabled by selecting the In the "Home" interface, select the "Gentle", "Soothing", "Strong" button to select the appropriate massage intensity.

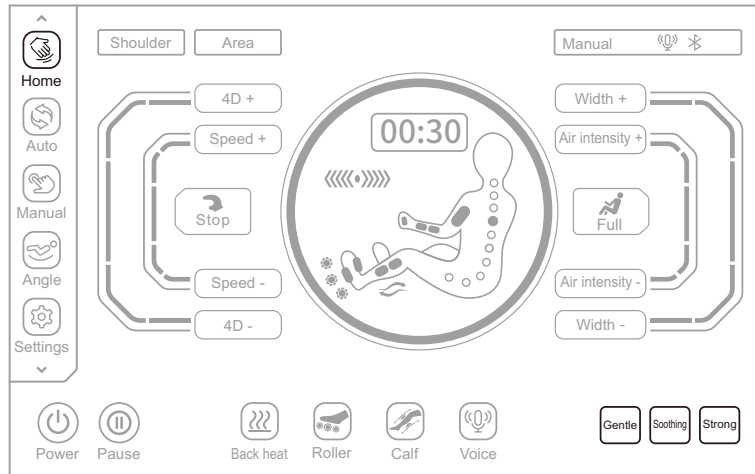

### XI.End massage

During massage, press the remote controller touch switch key (power icon) or press the right armrest switch key (power icon) to turn the equipment off. Immediately turn off all massage functions, reset the backrest unit and the leg unit, or when the massage timing time arrives, all massage functions will be automatically turned off, with the backrest unit and the leg unit not reset.

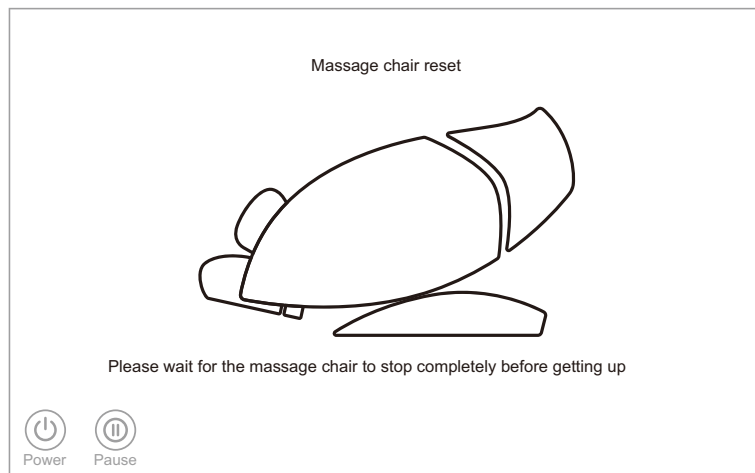

## Operation Instructions

Cut off the whole machine power supply, as shown in the figure (Schematic diagram of power switch position of the whole machine).

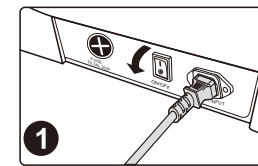

Turn off the power switch ("0" position)

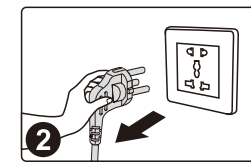

Schematic diagram of pulling out the power plug

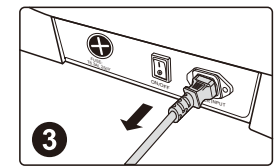

Remove the product connection power cord

## Cleaning and Maintenance

### Cleaning synthetic leather and plastic parts

Wipe the leather with a soft, dry cloth.

- Do not use chemicals such as thinner, gasoline, alcohol, etc. to clean the unit.
- When using commercially available leather care products (rags), please follow the instructions for use.
- If synthetic leather is particularly dirty, wipe it in the following way.
  - ① Immerse a soft cloth in water or hot water containing 3% to 5% neutral detergent, then wring it out thoroughly.
  - ② Use the above soft cloth to wipe the leather surface.
  - ③ Wipe off the cleaning solution with a cloth soaked in clean water and thoroughly wrung out.
  - ④ Wipe with a wrung soft cloth.
  - ⑤ Let it air dry naturally.
- When it is difficult to remove stains, please immerse commercially available melamine foam in neutral detergent, and then wipe the machine with it.
- Do not use a hair dryer to dry the surface.
- Be careful when wiping the machine with denim and colored fabrics, as the color of the fabric will stain the surface of the synthetic leather.
- Do not keep these parts in contact with plastic for a long time, as this will cause discoloration.
- Synthetic leather may be discolored, so when using hair dye, please cover the touched part with a towel.

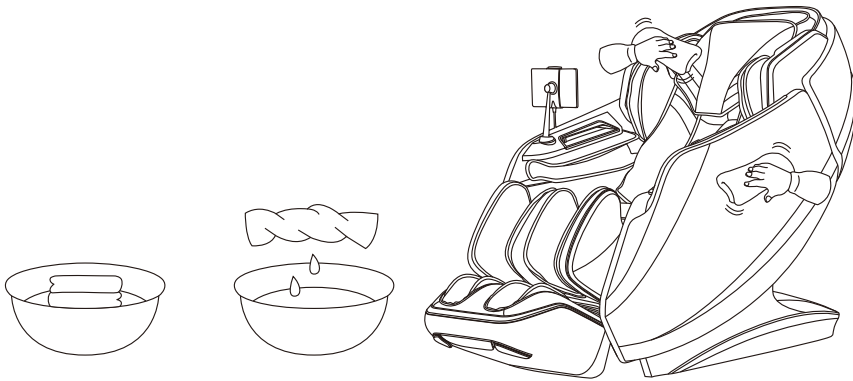

## Troubleshooting

|                 |   |
|-----------------|---|
| <b>Fault</b>    | When the calf mechanism or the backrest reaches a certain position, press the corresponding adjustment button and it will no longer change, and a continuous "beep, beep" sound will be emitted.                              |
| <b>Solution</b> | Due to product structure design and ergonomic requirements, this product has a limited protection design for the limit state of attitude adjustment. At the same time, a reminder sound will sound when the limit is reached. |

|                 |   |
|-----------------|---|
| <b>Fault</b>    | The function does not work or some functions do not work after the machine is turned on.  |
| <b>Solution</b> | After the machine is turned on by pressing the switch key, it is necessary to manually select an automatic massage program or other working state. If it is not operated, the machine will automatically shut down after 20 minutes. If the manual operation mode is selected, the functions that are not selected may be disabled, and the working mode needs to be manually set in the manual mode. |

|                 |   |
|-----------------|---|
| <b>Fault</b>    | The machine makes a leather rubbing sound when adjusting its posture.   |
| <b>Solution</b> | This product adopts high-grade anti-corrosion leather that meets environmental protection requirements. Due to the inherent characteristics of leather materials, there will be a normal slight noise when rubbing at the relative movement, which is a normal phenomenon. Note: If you hear fabric or leather tearing sound when the machine is running, please stop using it immediately and seek professional maintenance. |

|                 |   |
|-----------------|---|
| <b>Fault</b>    | The massage wheel did not reach the shoulders or neck.  |
| <b>Solution</b> | If the head does not touch the head cushion or the back does not touch the backrest, the shoulder position may be lower than the actual position during the body shape detection process. Sit in the deepest position of the seat, rest your head on the headrest, and start over from the beginning. |

|                 |   |
|-----------------|---|
| <b>Fault</b>    | The unit is damaged.<br>The power cord or power plug is abnormally hot. |
| <b>Solution</b> | To prevent accidents, be sure to contact an authorized service center.  |

Please feel free to contact the designated service personnel for any questions or doubts about this product.

## Product Specifications

---

Model: AI Revive 4D

Name: Massage Chair

Rated voltage: 110-120V~ 60Hz

220-240V~ 50Hz/60Hz

Rated power: 160W

Rated time: 20min

Safety structure: Class I